

WOOLIES



TRIM AND UPHOLSTERY FOR VINTAGE AND CLASSIC MOTOR ENTHUSIASTS WORLDWIDE

Open 0830-1700 Monday to Friday (closed lunch 1300-1400).



WOOLIES (I & C Woolstenholmes Ltd)
Whitley Way, Northfields Industrial Estate,
MARKET DEEPING, PETERBOROUGH,
England, PE6 8AR

Tel: (01778) 347347
www.woolies-trim.co.uk
info@woolies-trim.co.uk

22nd Edition



Hello and welcome to the 22nd edition of the WOOLIES catalogue. We have been supplying the Trade and the individual enthusiast for over 42 years with upholstery, trimmings and body fittings for vehicles dating back from early Vintage and Veteran right through to modern Classics and Kit Cars. More recently we have been supplying other non motoring sectors such as the film industry; our products can be used for all sorts of applications.

A large amount of business is now done via our easy to use, secure website. This is kept right up to date so has the very latest products and news and is a great tool to use in conjunction with the catalogue. If you have not used the website please go to www.woolies-trim.co.uk and have a look, you can get prices including postage and can order when the office is closed !

In addition to our Worldwide mail order service you can see us at selected Shows and Autojumbles during the year, please visit the website for information on the shows we will be attending. You can also visit us in person, we offer a 'counter service' and are open Monday-Friday 8.30am until 5pm but are closed between 1.00-2.00pm for lunch. We trust you will find the catalogue easy to use and informative and we look forward to helping all customers both old and new.

WOOLIES was started by Ian and Caroline Woolstenholmes in October 1976 from a double garage with a nominal stock, ultra keen prices and lots of enthusiasm. The Company now has a dedicated team lead by Directors Duncan Allen and Louise Woolstenholmes Green.

Duncan Louise

Nov 2018



INDEX

Acoustic foam.....10
Adhesives.....11/20
Aeroscreen.....26
Aluminium sections.....21/22
Aluminised heat mat & tape.....10/11

Badge bar and clips.....26
Battery master switch.....28
Bedford cord.....8
Body caulking.....19
Bonnet corners.....29
Bonnet catches/handles.....24/25/26
Bonnet tape and rivets.....23
Boot handle.....25
Boot seals.....4
Brass taps and fittings.....35
Brushed nylon seating.....8
Budget locks and key.....27
Bumper bolts.....29

Calico and platform cloth.....9
Carriage key.....27
Carpets and binding.....12
Celluloid.....7
Chalk.....8
Chrome strips (self adhesive).....5
Clevis pins.....29
Coach lacing.....4
Comp. boot/bonnet pins.....24
Copper tube.....35

Door buffers.....27
Door draught excluders.....3/4
Door check straps.....27
Door handles.....25
Door locks and strikers.....25
Drain tubing.....20

Eyelets (brass).....2
Exhaust insulating wrap.....11

Fasteners/clips.....1/2/12/14/23
Felt strips (black).....14
Floor lifting ring.....29
Foam cushion/sheet+scrim.....9

Gasket materials.....13
GB letters.....27
Gimp pins.....8
Glue gun.....11
Goggles.....28
Grease nipples (hex only).....29
Guttering.....22

Hardura felts.....10
Hammer (magnetic).....2
Hog rings and pliers.....2
Headlinings (wool, PVC and nylon).....7
Hessian.....9
Hide Food.....32
Hidem banding and caps.....8
Hood fastener.....29
Hood frame (hollow bar).....21
Hood Proofings.....6/7
Hoodings (Duck, 'Mohair' and Leathercloth).....6
Hook and loop tape.....8
Horn Bulb.....27
Horsehair (rubberised).....9

Interior pipings.....21
Interior handles.....25

Key hole covers.....27

Leathercloths.....5/6
Leather renovation kits.....30/31/32/33

Millboard (for trim panels).....9
Moquette and moleskin.....8
Mudguard bolts.....29

Over centre catches.....24
Override beading.....21

Pin beading.....21
Piping cord.....21
Pirelli webbing.....9

Reflectors.....28
Renovo hood products.....6/7
Rubber mattings.....20
Rubber extrusions/strip/tubing/flat smooth rubber.....17/18/19/20
Running board treads.....22

Screws (wood & self-tap).....23
Shears (scissors).....3
Self-adhesive sponge sheeting and strip.....15/16/19
Sidescreen fittings.....29
Sound damping sheet/pads.....10
Spoke cleaning brushes.....27
Sponge extrusions.....16/17
Spring binding tape.....29
St George Cross.....27
Staples (for strapping).....27
Staple gun.....2
Storvic heel pads.....12

Tacks and escutcheon pins.....8
Thread.....8
Tools (fitting).....2/20

Underfelts.....10
Union jacks.....27
Upholstery needles.....8

Velvet (thin black).....14
Vinyl paint.....34
Vinyls.....5/6
Vybak.....7

Wadding.....9
Webbing.....6/9
Window channels.....13
Window weatherstrips.....14
Window winder.....25
Windscreen filler inserts.....19
Wing pipings.....21

Zips.....8

ALL RIGHTS RESERVED. No part of this catalogue may be reproduced or transmitted in any form without the permission of I & C Woolstenholmes Ltd t/a "WOOLIES"

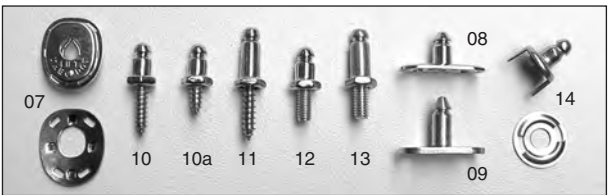

Lift the Dot Fasteners (Plated)

- 07 Socket with backplate Pkt 10
- 07a Long-pronged socket with backplate (NOT shown) Pkt 10
- 08 Single thickness screw base stud Each
- 09 Double thickness screw base stud Each
- 10 Single thickness wood screw stud Pkt 10
- 10a As 10 but shorter thread approx 10mm (3/8") Pkt 10
- 11 Double thickness wood screw/self tapper stud Each
- 12 Single thickness metal stud Pkt 10
- 13 Double thickness metal stud Each
- 14 Single clinch stud (cloth mounted) with backplate Pkt 10



Durable Dot Fasteners (Plated)

- 15 Button and socket 13mm (1/2") dia. Pkt 10
- 15a Button and socket 15mm (9/16") (NOT shown) Pkt 10
- 15b As 15a but LONGER shank for thicker fabric Pkt 10
- 15c As 15a but black PVC coated button top Pkt 10
- 16 Stud for wood or metal Pkt 10
- 17 Stud and eyelet for cloth mounting. 6mm shank Pkt 10
- 17a As 17 but 9mm shank for thicker fabric Pkt 10

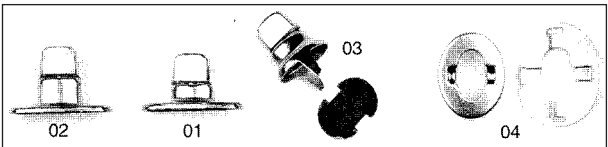

Turnbuckle Fasteners (Plated)

- 01 Single thickness screw base stud Pkt 10
- 02 Double thickness screw base stud Pkt 10
- 03 Single clinch stud (cloth mounted) with backplate Pkt 10
- 04 Socket with backplate Pkt 10

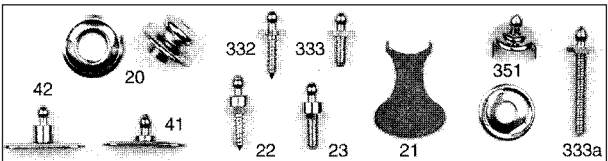

Tenax Snap Fasteners (Plated)

- 20 Spring loaded socket with nut Pkt 10
- 20a Extra length socket for THICKER fabric (NOT shown) Pkt 10
- 21 Key for tightening above Each
- 22 Wood screw stud with 'shoulder' as shown Each
- 23 Metal screw stud with 'shoulder' as shown Each
- 332 Wood screw stud WITHOUT 'shoulder' Pkt 10
- 333 Metal screw stud WITHOUT 'shoulder' Pkt 10
- 333a As 333 with thread 25mm (1") long Pkt 10
- 351 Single clinch stud (cloth mounted) with backplate Pkt 10
- 41 Platform stud WITHOUT 'shoulder' Pkt 10
- 42 Platform stud with 'shoulder' as shown Pkt 10

All the metal screw studs on this page have a 2BA thread or similar and we can supply supply nuts/washers to suit (see 239 below).

- 239 Steel nuts and spring washers (NOT shown) Pkt 10



- 331 Black plastic trim button. 15mm (9/16") dia. head with serrated body 16mm (5/8") long. For thin or nominally padded panels Pkt 10
- 260 For hole or edge fitting 15mm (9/16") reach Pkt 10
- 261 Spring Clip 11mm (7/16") reach for weatherstrips etc. Pkt 10
- 262 'U' Spring Clip 4.7mm (3/16") gap Pkt 10
- 314 'U' Spring clip. Narrow fitting for use in conjunction with 235 and 138 push-on edge trims on page 3 Pkt 10

TOOLS & EYELETS

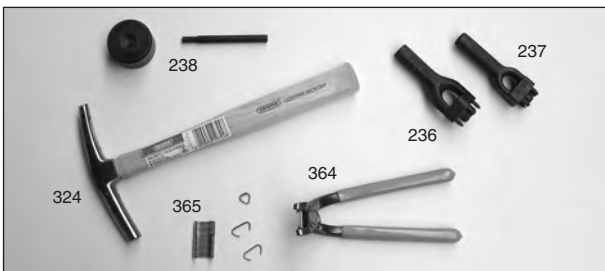

- 236 Turnbuckle Punch for fitting 04 Each
- 237 Lift-the-Dot Punch for fitting 07 and 07a Each
- 238 Durable-Dot double sided bed and punch. One side is used for the 15 and 15a button and the other for the 17 stud Per set
- 324 Magnetic Hammer. 26.7cm (10 1/2") overall length. Wooden shaft. 13mm (1/2") dia. head. For 'tacking' the professional way Each
- 364 Hog Ring Pliers. Angled head. Spring-loaded, grooved jaws grip the hog ring. A firm squeeze clamps the ring Each
- 365 Hog Rings. Supplied in sticks of approx. 60 Per stick
..... Per 10 sticks
..... Per bulk box approx. 8800

Refer to page 20 for Universal Fitting Tool for windscreen rubbers



- 389 **Brass Eyelet Kits.** Complete with punch and die.
25 brass eyelets & rings 10mm (3/8") dia. hole Per kit
15 brass eyelets & rings 13mm (1/2") dia. hole Per kit
- 390 **Brass Eyelets ONLY.**
25 brass eyelets & rings 10mm (3/8") dia. hole Per pack
15 brass eyelets & rings 13mm (1/2") dia. hole Per pack
- 391 5/16" Hole Cutting Punch for 3/8" dia. eyelets or No. 20 Tenax... Each
7/16" Hole Cutting Punch for 1/2" dia. eyelets Each
- 392 Heavy Duty Staple Gun Tacker Rapid 33. Each
- 393 Staples to suit above gun. 4mm leg length Per box 5000
6mm leg length Per box 5000
8mm leg length Per box 5000
- 394 Tailors Shears as used by the Trade. 10" Each
12" Each

DOOR/BOOT SEALS & EDGE TRIMS

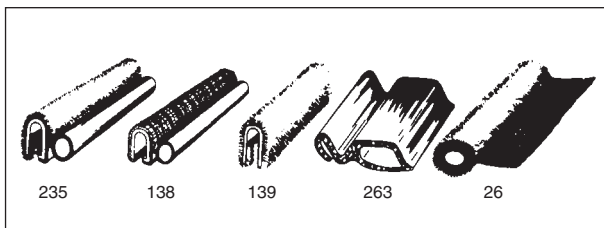

- 235 **Plush Snaddon and Rubber.** 'U' shaped soft alloy covered in plush material with 10mm ($\frac{3}{8}$ ") rubber bead attached. Push-on fit. Stocked in black, red, cinnamon, grey, brown, green, blue, light beige and mulberry. Needs 314 spring clip for tight 'grip' Per mtr
- 138 **Woven Snaddon and Rubber.** Same soft alloy inner and rubber bead as 235, but covered in woven repp material. As fitted to Morris Minors, A30/35 etc. Stocked in black, red, grey, green and standard blue. Needs 314 spring clip for tight 'grip' Per mtr
- 139 **Plush Snaddon Edge Trim.** 'U' shaped steel covered in plush material. Tight push-on fit. Stocked in black, red, navy, grey, mid-green, suede green, dark brown, blue, cinnamon, light beige and mulberry Per mtr
- 139a **LARGER Plush Snaddon Edge Trim.** 22mm ($\frac{7}{8}$ ") overall height and 17mm ($1\frac{1}{16}$ ") overall width. Same 'U' shaped steel as 139 plus integral rubber padding. Stocked in black and beige. NOT shown..... Per mtr
- 263 **Ramsey Sponge Door Seal.** As fitted to the Jaguar XK150 and MkVII saloons. Supplied 'hollow' to make it more collapsible. Needs 139 plush edge or 303 woven edge (see page 4) to complete. (We suggest that samples be requested for trials initially) Per mtr
SPECIAL TRADE PRICES ON 100mtr (328ft) ROLLS.
- 26 **Furflex Draught Excluder.** Plush wool moquette covered bead approx. 16mm ($\frac{5}{8}$ ") OD with canvas flange 24mm ($1\frac{5}{16}$ ") wide. Used on Vintage cars and Classics like the Jaguar MkII saloon. Stocked in black, red, mulberry, brown, dark and suede green, Jaguar navy, standard blue, light beige, dark beige, cinnamon and grey Per mtr

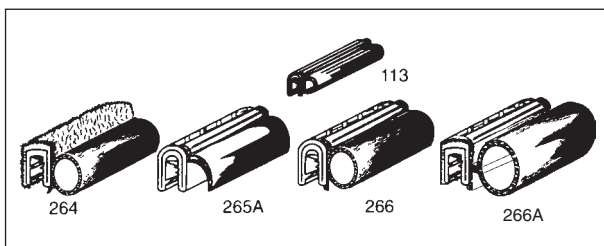

- 264 **Plush and Sponge Snaddon with 18mm ($1\frac{1}{16}$ ") OD sponge piping** attached. Inner spring wire 'U' carrier for a tight push-on fit. Black, light blue, grey, beige, brown and red Per mtr
- 265A **Rubber covered Snaddon with Sponge Flap** protruding 11mm ($\frac{7}{16}$ "). Useful for tight fitting doors, as flap will crush easily .. Per mtr
- 266 **PVC Snaddon with Sponge Bead** 16mm ($\frac{5}{8}$ ") dia. Black herringbone pattern embossed PVC carrier Per mtr
- 266A **Rubber covered Snaddon with Very Large Sponge Bead** 19mm ($\frac{3}{4}$ ") dia. Similar to 266 but with larger sponge bead and 'squarer' push-on that will cope with up to a 4mm thick flange..... Per mtr
- 113 **Miniature rubber covered door seal** 6mm ($\frac{1}{4}$ ") dia. bead. Self gripping. Very bendable for tight corners Per mtr

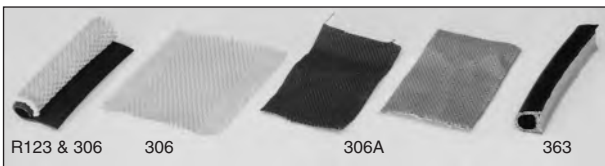

- 363 **Hollow Self Adhesive 'D' Sponge.** Very collapsible. May need extra adhesive applying. Approx. 13mm (½") wide Per mtr
- R123 **Split Tube Rubber Draught Excluder.** As used on the MG 'Y' type, Morris series 'E' and similar. Shown with beige coach lacing. Supplied under this part number as RUBBER ONLY Per mtr
- 306 **Beige Coach Lacing.** Approx. 75mm (3") wide. Cotton-type woven lacing available in beige only. Can be dyed to choice. For making pipings, edgings or to cover the R123 as shown Per mtr
- 306A **Heavy Cotton Lacing.** 54mm (2½") wide. Black, grey and red only. Ideal for making pipings, using 29 piping cord on page 21 or 254 sponge cord on page 17, even covering the bead on R123...Per mtr

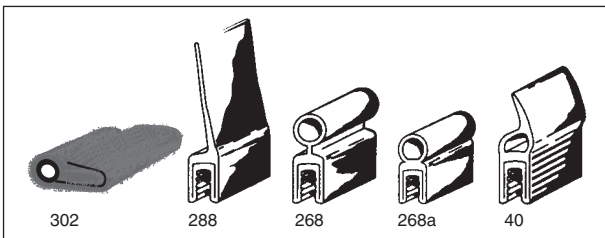

- 302 **Jaguar XJ6 Draught Excluder** for fitting onto horizontal flange. Ex-stock in black, light beige, grey, blue and cinnamon Per mtr
- 288 **Mud flap push-on (or tall boot seal).** Rubber covered. Vertical flange protrudes 29mm (1½") Per mtr
- 268 **Rubber and Sponge Boot Seal.** Inner spring wire carrier covered in black rubber. Bead standing up 13mm (½") Per mtr
- 268a **Rubber and Sponge Smaller Boot Seal.** Inner spring wire carrier covered in black rubber. Small sponge bead standing up 8mm (5/16") Per mtr
- 40 **Flap and Bead Sponge Boot Seal.** Self gripping. Flap 16mm (5/8") tall Per mtr

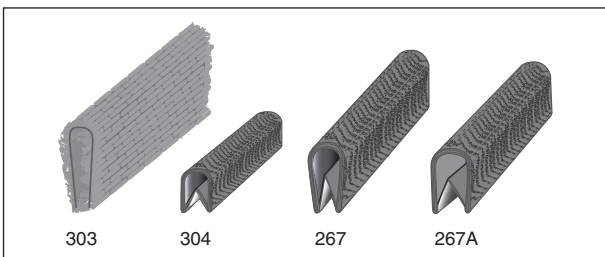

- 303 **Woven Snappan Edge Trim.** 'U' shaped steel inner covered in woven cotton type repp material. Stocked in black, grey and red. Can be used with 263 Ramsey sponge (see page 3) to make complete door seal.Per mtr
- 267 **PVC Edge Trim.** Herringbone embossed PVC.
Black Per mtr
Colours (green, red, very light grey, mid grey, white and mid blue) Per mtr
- 304 **Titanfast Black Edge Trim.** Only 10mm (3/8") tall. Miniature version of 267 that will bend round a 19mm (3/4") radius Per mtr
- 267A **Wider PVC Edge Trim.** Embossed black only. Squarer carrier to cope with up to 4mm thick flange Per mtr



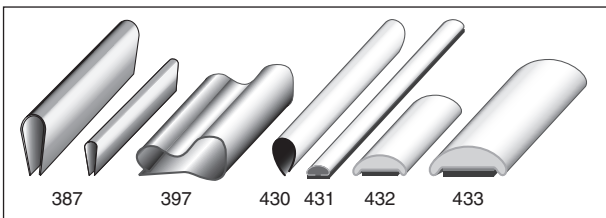

- 387 **'Chrome' Plastic Edge Trim** in 2 sizes:
 4.7mm ($\frac{3}{16}$ ") tall for 1mm thick flange Per mtr
 11mm ($\frac{7}{16}$ ") tall for 2.5mm thick flange Per mtr
- 397 **Mini Wheelarch plastic edge trims** 'Chrome' finish Per mtr
 Black finish Per mtr
- 430 **'Chrome' Self Adhesive Edge Trim.** High shine finish. 9mm ($\frac{11}{32}$ ") tall for up to 3mm ($\frac{1}{8}$ ") thick flange. Small "tacky" strip inside to help it grip onto edge Per mtr
- 431 **Self Adhesive 'Chrome' Plastic Strip.** 4mm ($\frac{5}{32}$ ") wide. High shine finish Per mtr
- 432 **Self Adhesive 'Chrome' Plastic Strip.** 9mm ($\frac{11}{32}$ ") wide. High shine finish Per mtr
- 433 **Self Adhesive 'Chrome' Plastic Strip.** 12mm ($\frac{1}{2}$ ") wide. High shine finish Per mtr

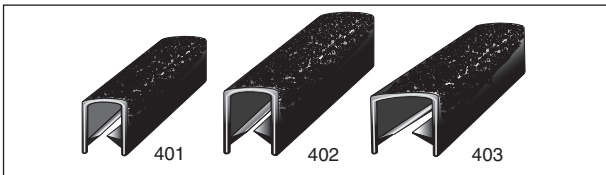

Larger Black PVC Edge Trims. SQUARER carrier and different grained finish to other PVC edge trims.

- 401 12.5mm ($\frac{1}{2}$ ") tall to fit 6.3mm ($\frac{1}{4}$ ") thick flange Per mtr
- 402 16.5mm ($\frac{11}{16}$ ") tall to fit 8mm ($\frac{5}{16}$ ") thick flange Per mtr
- 403 15mm ($\frac{19}{32}$ ") tall to fit 12.5mm ($\frac{1}{2}$ ") thick flange Per mtr
 Large rolls, approx. 76mtr. Please enquire for roll discounts.

VINYLS & LEATHERCLOTHS

- 25 **Expanded Vinyl.** 137cm (54") wide. For all interior work, with just the right amount of stretch. Stocked in black, red, maroon, brown, grey, dark blue, mid blue, green, beige, biscuit, barley, cream and off-white. Colour samples on request..... Per mtr
- 25a **Black 'Clearance' Expanded Vinyl.** 137cm (54") wide. A good value product but stock can vary Per mtr
- 242 **Non-stretch Vynide.** 127cm (50") wide. Ideal for trim panels and thin enough for pipings. Stocked in burgundy, morello (very dark maroon) and black grained Per mtr
- 242a **Black smooth grain non-stretch Vynide.** 127cm (50") wide. Per mtr
- 18 **Special Jaguar non-stretch Vinyl.** 127cm (50") wide with a good grain. Stocked in magnolia, old beige, dark beige, barley, doeskin, blue/grey, grey, cinnamon, mulberry, red, suede green, dark blue, dark green, cream, white and black Per mtr
- 19 **Special Jaguar Ambla,** colour coded to the above vinyl. 127cm (50") wide. Stocked in beige, suede green, cinnamon and tan Per mtr.
- 250 **Old Fashioned vinyl leathercloth** Non-stretch. Mottled green (Evergreen) and a mottled brown (Spice). 127cm (50") wide Per mtr
- 286 **Antique Grained Leathercloth.** 127cm (50") wide. A really firm, rexine-type of leathercloth with heavy grain, Can be used for some exterior applications. In black only Per mtr
- 100 **Special Mini Cooper Light Green Vinyl.** 127cm (50") wide. Per mtr

- 323 **Perforated and Fluted Black Expanded Vinyl.** Ready made heatformed flutes 32mm (1¼") wide. Nominal 3mm (⅛") thick foam backing. The small 'square' perforations do NOT penetrate surface completely. 140cm (55") wide Per mtr
- 370 **Basketweave Black Expanded Vinyl.** 141cm (55½") wide. Ideal for Classic seat inserts Per mtr

HOODING MATERIALS

- 24 **Exterior Quality Leathercloth** for hooding, tonneau covers and body fabric 137cm (54") wide. Stocked with grained finish in black, red, dark blue, very dark green, beige, biscuit, grey, maroon, off-white, cream and brown.
 Black only Per mtr
 Colours Per mtr
 The grain and texture of 24 exterior quality are comparable to some of the early rexine-type materials and customers with earlier vehicles may prefer to use this for interior work.
- 415 **Ribbed Exterior Leathercloth** 150cm (59") wide. Stocked in black with ribbed effect. For hooding, tonneau covers and body fabric. Very limited stretch, needs warming up to stretch over curves. Can be used as internal vinyl Per mtr
- 183 **CABRIO VINYL HOODING IN BLACK.** 150cm (59") wide. Heavy vinyl coated hooding with fine pebble grain. Water repellent black underside of cotton-based cloth Per mtr
- 269 **Heavy Double Duck hooding** 190cm (75") wide. Stocked in black. Comparable to the pre-war quality duck Per mtr
 Fawn 170-178 cm (67"-70") wide, ex stock Per mtr
- 30 **Wigan Weave Double Duck hooding** 178/183cm (70/72") wide. Finer weave and generally lighter weight than No. 269. Stocked in black only Per mtr
 Both Duck hoodings are produced from vat-dyed cloth therefore a certain amount of shade variation and general fading may occur. FAWN duck is particularly prone to sun fading.
 NOTE THAT SHRINKAGE ON THE COTTON DUCK HOODINGS IS LIABLE TO BE 2%, so please make allowance when fitting
- 179 **TWILLFAST Convertible Acrylic Hooding.** 150cm (59") wide. Solution dyed 100% acrylic exterior fabric with twill weave giving superior fade resistance, combined with beige Dobby lining. Black, blue, fawn and green. Also black with black dobbie lining. Per mtr
- 287 **Dobby Lining.** 150cm (59") wide. Beige thin lining material with herringbone pattern as used on underside of 179 hoodings. Per mtr

HOODCARE, WEBBING & WINDOWS

- 407 **Twillfast Hood Binding.** 32mm (1¼") wide. Single thickness Twillfast without the herringbone backing in black, blue and fawn. Per mtr
- 31 **Hood Webbing.** 50mm (2") wide. Black and beige Per mtr



- 381 **Renovo Hood Reviver.** Re-colours and re-conditions canvas, Double Duck and Mohair hoods (NOT VINYL hoods). Best results when used with 382 pre-cleanser/shampoo. Works very well on really old and faded hoods.. Available in black, dark blue, and brown Per ½ litre bottle
 Per 1 litre bottle



- 382 **Renovo Pre-cleaner/Shampoo.** For preparation of canvas hood BEFORE Hood Reviver application and for regular cleaning. Removes grime and ingrained dirt without impairing appearance of the fabricPer 500ml bottle
- 383 **Renovo Ultra Proofer.** Re-establishes original waterproof weather barrier and helps prevent road grime, salt, leaf gum and bird dirt from harmful penetration deep into fibres of hood material. Contains UV additive and anti-mould agent. Leaves the double duck and mohair both water AND stain repellent Per ½ litre bottle
..... Per 1 litre bottle



- 384 **Renovo Plastic Window Polish.** Restores transparency, reduces scratches and staining and cleans and conditions. Rub in with soft cotton cloth, allow to dry then polish off Per 50ml bottle
..... Per 100ml bottle
- 404 **Renovo VINYL Soft Top Cleaner.** For PVC hoods/tonneaus. Needs
405 Ultra Proofer to complete the renovation Per 500ml
- 405 **Renovo VINYL Ultra Proofer.** Helps prevent build-up of road grime, salt, leaf gum and bird dirt and resists weathering with UV inhibitor. Ideally needs 404 cleaner to prepare surface Per 500ml
- 35 **Celluloid.** A rigid clear material that gives minimum distortion when used for sidescreens. Stocked in sheets. 127cm x 66cm x 0.75mm (50" x 26" x .030") Per sheet
- 34 **Vybak.** Flexible window sheeting. Durable, heavy-duty clear material for rear windows in folding hoods:
1/3 sheet 41cm x 125cm x 0.75mm (16" x 49") Per sheet
Full sheet 125cm x 125cm x 0.75mm (49" x 49") Per sheet
LARGE sheet 250cm x 125cm x 0.75mm (98"x 49") Per sheet

HEADLININGS

- 270 **PVC Headlining.** 137cm (54") wide. Light grey and white with lightly embossed pattern as used on Morris Minors and similar Per mtr
- 334 **Perforated PVC Headlinings.** 137cm (54") wide. Choice of off-white, grey and black..... Per mtr
- 285 **Nylon Headlining Foam backed.** As used on Jaguars and similar from the 50's and on. Stocked in Dove Grey (mid grey). Width can vary between 127cm and 150cm (50" and 59") so please ask before ordering Per mtr
- 285a **Special Nylon Headlining Foam backed.** Thin foam inner layer backed with woven nylon fabric. Stocked in Cashmere (beige) Width can vary between 127cm and 150cm (50" and 59") so please ask before orderingPer mtr
- 32 **Headlining.** A good, basic quality Union Melton cloth 150cm (59") wide. 80% wool 20% nylon mix. Open weave with sparse nap. Stocked in beige, camel, grey and black Per mtr
- 142 **Headlining.** All wool 'West of England' type cloth 150cm (59") wide. One of our better quality plain cloths available from stock in beige and grey Per mtr
- 33a **Headlining.** All wool cloth in dark red 2mtr (78¾") wide. A really top quality cloth Per mtr

SEATING CLOTHS

- 143 **Heavy All Wool Cloth.** Heavy enough for seating AND headlining quality. Beige, grey, dark green and light green 190cm (75") wide.Per mtr

- 322 **Plain Seating Cloth 'Moleskin'**. 152cm (60") wide. All cotton, very hard wearing fabric for seating or headlining with nap on one side only. Stocked in light beige Per mtr
- 271 **Bedford Cord**. Heavy pre-war seating quality 152cm (60") wide. Ex-stock in beige and grey. Per mtr
- It is worth mentioning that this Bedford Cord has been successfully used 'upside down', both as a plain seating cloth and as a robust headlining. In this way, a matching combination of ribbed and plain cloth can be successfully achieved.
- 247 **Moquette**. Plush wool pile 127cm (50") wide. As used on seat backs, trim panels, rear wheel arches of Classic Cars. A good range of colours. Suede green, grey, dark blue, mulberry, black, beige and red Per mtr
- 272 **Brushed Nylon Foam Backed**. 137cm (54") wide. Plain plush upholstery material available in grey, dark blue and black Per mtr

TRIMMING SUNDRIES

- 148 **Zip**. Heavy duty 107cm (42") zip with closed end. Nickel on brass. Black and fawn Each
- 148a **Zip**. As above but 92cm (36") long Each
- 29 **Piping Cord**. 3mm (1/8") dia. For seat piping or making hidem ie. can be covered with headlining material or thin leathercloth Per mtr
- 273 **Hook and Loop 'Touch and Close Fastener'**. An alternative to conventional fasteners where two overlapping surfaces need a positive location and yet be easily detachable ie., tonneau cover, carpet, inspection flaps.
- 16mm (5/8") wide. Black Per mtr
- 25mm (1") wide. Black Per mtr
- 50mm (2") wide. Black Per mtr
- 273a **Self Adhesive Hook and Loop**. As above, but with good quality pressure sensitive adhesive suitable for a wide range of surfaces. Sample snippets can be supplied for TESTING adhesion.
- 16mm (5/8") wide. Black Per mtr
- 25mm (1") wide. Black Per mtr
- 50mm (2") wide. Black Per mtr
- 149 **Chalk**. Tailor's marking chalk white and various colours Each
- 147 **Tacks**. Blue cut 13mm (1/2") Per 35g (1 1/2oz) bag
- 219 **Escutcheon Pins**. 13mm (1/2") long. 16g. Nickel/Brass Pkt/10
- 220 **Escutcheon Pins**. 19mm (3/4") long. 16g. Nickel/Brass Pkt/10
- 396 **Gimp pins**. 13mm (1/2") Per 100grm bag
- 19mm (3/4") Per 100grm bag
- 45 **Upholstery Needle**. Curved Each
- 39c **Thread**. Grade 36 poly-cotton. 800mtr spool. Good range of colours for all work, please enquire Each
- 412 **Thread**. Thick heavy grade 20 bonded nylon. Large spool ideal for trade users. 1500mtr. Stocked in black, beige and grey Each

HIDEM BANDING

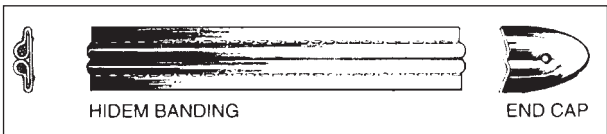

- 27 **Hidem Banding** 16mm (5/8") wide. Grained leathercloth. Stocked in biscuit, black, red, maroon, brown, green, doeskin, blue, grey and magnolia Per mtr
- 140 **Hidem Banding** 13mm (1/2") wide. Grained leathercloth finish, stocked in black and doeskin only Per mtr
- 418 **Duck Hidem Banding**. Black Cotton Duck. Used as a finisher across the front of hoods. 16mm (5/8") wide Per mtr
- 240 **Hidem Banding Cloth Covered**. 16mm (5/8") wide. Beige, camel and grey that complement No. 32 and 142 headlinings Per mtr
- 28 **Hidem End Caps** to suit 16mm (5/8") hidem only. Nickel plated on BRASS so suitable for exterior work Each
- 28a **Brass Hidem End Caps** as 28 but brass finish. Each

PIRELLI WEBBING

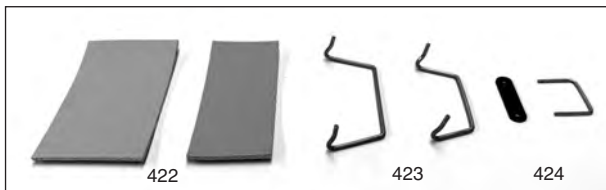

- 422 **Pirelli Webbing.** Beige rubberised strip used for seat bases. Approx. 10% stretch. Can be tacked, stapled or use wire clips, see 423 and 424 below.
 38mm (1½") wide Per mtr
 50mm (2") wide Per mtr
- 423 **Pirelli Webbing Wire Clips.** Use in conjunction with 424 staple/plates. Wire clips fix to holes in seat frame.
 38mm (1½") wide Pkt/10
 50mm (2") wide Pkt/10
- 424 **Pirelli Webbing Staple/Plates.** Wire staple and plastic plates. Use in conjunction with 423 wire clips. Each packet has 10 x staples and 20 x plates Per pkt



Federation of British Historic Vehicle Clubs

We are pleased to be members of the Trade Support Scheme of the FBHVC, who strive to "ensure that club members and their vehicles continue to enjoy the freedom of the use of the roads in the United Kingdom and Europe".

FILLINGS, FOAM & MILLBOARD

- 37 **Wadding.** In 10mtr x 46cm (11yd x 18") bundles. White cotton wool type material. Used as single or multiple layers and for stuffing seat flutes Per bundle
- 38 **Hessian.** 183cm (72") wide for covering seat frames or similar before trimming Per mtr
- 244 **Calico.** 137cm (54") wide. Off-white colour Per mtr
- 94 **Platform Cloth.** 137cm (54") wide. Thin BLACK calico-type fabric for covering non-wearing surfaces ie. under seats Per mtr
- 328 **High Resilient Foam Sheeting.** Combustion Mod. to BS 5852. Available in full sheets 239cm x 203cm (94" x 80") and in 13mm, 25mm, 38mm, 50mm, 75mm and 100mm thickness. Half AND quarter sheets available *pro-rata*. Makes a very good combination of firmness plus comfort when used with our No. 36 rubberised horsehair.
 239cm x 203cm x 13mm (94" x 80" x ½") Per sheet
 239cm x 203cm x 25mm (94" x 80" x 1") Per sheet
 239cm x 203cm x 38mm (94" x 80" x 1½") Per sheet
 239cm x 203cm x 50mm (94" x 80" x 2") Per sheet
 239cm x 203cm x 75mm (94" x 80" x 3") Per sheet
 239cm x 203cm x 100mm (94" x 80" x 4") Per sheet
 CUSHIONS 56cm x 51cm x 100mm (22" x 20" x 4") Each
 This foam should NOT be confused with the average 'market' quality. Please ALLOW FOR CARRIAGE if ordering full sheets of foam.
- 133 **Foam Sheeting.** 6mm (¼") thick and approx. 2.1mtr (84") wide. A very collapsible foam ideal for nominal padding Per mtr
- 380 **Scrim Foam.** Foam with a thin backing so suitable for stitching.
 3mm (⅛") thick, 127cm (50") wide Per mtr
 6mm (¼") thick, 137cm (54") wide Per mtr
 12mm (½") thick, 137cm (54") wide Per mtr
- 48 **Millboard.** 2.3mm (⅜") thick. Compressed card consistency with one side faced black and lightly grained. Ideal for trim panels. Stocked in sheets approx. 155cm x 122cm (61" x 48") Per sheet
- 36 **Rubberised Horsehair.** Synthetic preparation that gives a 'firm seat' without the lumpiness of the genuine horsehair. Flame retardant. Stocked in sheets 183cm x 91.5cm x 2.5cm (6' x 3' x 1") Per sheet

FELTS & SOUND DAMPING

- 136 **Felt.** 6mm (1/4") thick for sound deadening under carpet or trim. 137cm (54") wide Per mtr
- 137 **Felt.** 11mm (7/16") thick for sound deadening as above. 137cm (54") wide and unbacked Per mtr
- 241 **Hardura Felt.** 137cm (54") wide felt coated on one side with tough, durable PVC with an embossed finish. Approx. 3mm (1/8") thick. Original equipment for lining luggage space in many classic cars. Ex-stock in black, dark blue, red, biscuit, 'suede green', beige and grey Per mtr
- 241a **Heavy Hardura Felt.** Approx. 132cm (52") wide. Varies 6mm-10mm (1/4"-3/8") thick with tough, durable PVC coating with an embossed finish. As used on the early Jaguar XJ6 and Minis. Can be used under bonnet, engine bulkheads or extra noisy areas where a wipe-clean surface is preferred. Stocked in black only Per mtr
Allow for CARRIAGE due to BULK of this Heavy Hardura.
- 349 **Ribbed Hardura Felt.** 137cm (54") wide. Black PVC coated felt with ribs 3mm (1/8") wide running across the roll. Approx. 6mm (1/4") thick Per mtr
Colours also available in dark blue, red and biscuit 137cm (54") wide Per mtr
- 292 **Sound Deadening Felt.** Approx. 13mm (1/2") thick, 137cm (54") wide. One side coated in black latex solution. Fire resistant to FMVSS 302. A really good dense felt Per mtr
- 135 **Sound and Vibration Damping Pads.** 1.6mm thick (just under 1/16"). Self Adhesive. For inside doors, roofs, bulkheads and floors. Cut to size/shape BEFORE backing paper is removed. Make sure surface to be applied is completely clean. Peel backing and press firmly into place. Both pad and adhesive can withstand temperatures between -30°C and +120°C and are highly resistant to aging. For best results the temperature of the pad and application surface should NOT be below room temperature. Product is VERY FRAGILE WHEN COLD.
Pad approx. 51cm x 18cm (20" x 7") Each
Half sheet 75cm x 1mtr (29 1/2" x 39") Each
Full sheet 1.5mtr x 1mtr (59" x 39") Each
- 409 **Acoustic Foam.** 12mm (approx. 1/2") thick. Fire retardant (self extinguishing FMVSS302). Bonded to a self adhesive sound and vibration damping sheet. To reduce both panel resonance and sound. Sheet size 1 1/2mtr x 1mtr (59" x 39 1/4")..... Per sheet
- 410 **FOIL COATED Acoustic Foam.** As 409 above but with added benefit of a heat reflective foil facing which will withstand up to 250°C. Is ideal for under bonnet or any area where heat deflection is required. Sheet size 1 1/2mtr x 1mtr (59" x 39 1/4") Per sheet

HEAT RETENTION & DEFLECTION

- 367 **Aluminised Heat Barrier.** Flexible high temperature insulation. Used as a heat shield, the barrier should be installed with highly reflective metallic surface facing the heat source. To RETAIN heat, position with FABRIC side facing the heat. 1mtr (39") wide per mtr
- 368 **Thermo Shield Self Adhesive Tape.** Roll 38mm (1 1/2") wide x 4.57mtr (15ft) long x approx. 1mm thick. Very flexible high silica fibre with metallised mirror finish. For wrapping/protecting any hoses, fuel lines, wiring etc. from damaging engine/exhaust heat. Can be fitted *in situ* without removal/disconnection of components. Per roll
- 428 **Acoustic Heatshield.** Long strand glass fibre needlemat faced on one side with reinforced aluminium foil and self adhesive backing on reverse side. Approx. 7mm thick. Provides both thermal and acoustic insulation. The reflective face can withstand radiant heat up to 250°C while the adhesive backing can be used at continuous temperatures up to 180°C.
Pad approx. 40cm x 50cm (16" x 20") Each
Half sheet 80cm x 1mtr (31 1/2" x 39") Each
Full sheet 1.6mtr x 1mtr (63" x 39") Each





379 Exhaust Insulating Wrap. 1.5mm (1/16") thick. For wrapping around exhaust manifolds and down pipes. Asbestos free, silicon based wrap. 6mm (1/4") overlap recommended. Reduces under bonnet heat by up to 75%, increasing power and fuel efficiency. Will withstand up to 2000°F.

25mm (1") x 15.23mtr (50ft) long Per roll
 50mm (2") x 15.23mtr (50ft) long Per roll

A guide to coverage per 30cm (1ft) of pipe as follows:
 38mm (1 1/2") dia. pipe uses 1.83m (6ft) of 25mm (1") wrap
 50mm (2") dia. pipe uses 2.5m (8ft 2") of 25mm (1") wrap
 50mm (2") dia. pipe uses 1.12m (44") of 50mm (2") wrap
 75mm (3") dia. pipe uses 1.45m (57") of 50mm (2") wrap

ADHESIVES

329 Aerosol Adhesive. 500ml aerosol tin ideal for all upholstery, felts and 328 foam sheeting. Adjustable nozzle for fine, medium or heavy spray coating Per can

376 Aerosol High Heat Adhesive. 500ml. Remains effective up to 120°C (248°F). Adjustable nozzle for fine, medium or heavy spray coating. Ideal for the high temperatures experienced in automotive use (headlinings, bulkheads etc). A useful alternative to our 259 high heat 1 litre tins Per can

52 Adhesive Thixofix/AF172. Slow contact adhesive ie. can be manoeuvred into position. For cloth to metal/wood Per 1/2 litre tin
 Per 1 litre tin

277 Adhesive S758/AF176. General purpose contact, for PVC, leather-cloth, rubber to metal/wood Per 1/2 litre tin
 Per 1 litre tin

259 Adhesive S1358/AF178. High heat resistant, ie. ideal for vinyl roofs. The STRONGEST of our adhesives Per 1 litre tin

366 Glue Gun. As used by the trade. Suitable for all above adhesives EXCEPT 52 Thixofix. Approx. capacity 0.25ltr Each

366b Spare Brush for glue gun Each



281 Locite Super Glue. Ideal for our rubber/sponge extrusions on to metal, painted surfaces, wood plus some fabrics and plastics. Careful use could give up to 120-152cm (4-5ft) run per 1 gram of glue Per 3grm tube
 Per 5grm bottle

476 Aerosol Solvent Cleaner. 500ml. Designed to remove excess adhesive/oil/grease. Works on carpet, fabrics, trim and most other surfaces. Do A TEST area first to determine suitability. Per can

CARPETS

- 57a **Carpet** 150cm (59") wide. Rubber backed tufted carpet with a good pile. Needs binding. A good range of colours: black, red, fawn/sand, maroon, dark blue, beige, dark green, brown and grey Per mtr
- 421 **Budget Carpet black/charcoal.** 107cm (42") wide 100% Polypropylene. A soft piled budget carpet with pliable rubber backing Per mtr
- 413 **Rotproof Lining Carpet.** 2mtr (78") wide. Loop pile, soft, very flexible lining carpet. Not suitable for heavy wear areas but ideal for e.g. side walls, approx. 5mm ($\frac{3}{16}$ ") thick. Polypropylene, non-fray type. Stocked in black, blue and red Per mtr
- 290a **Wool Pile Carpet.** 107cm (42") wide. Close 100% wool pile in a firm but pliable rubber backing, original quality produced for Jaguar and similar in the 1950s. Stocked in light and dark beige, black, light and dark blue, cinnamon, red, dark and suede green, brown, mulberry and grey Per mtr
- 291 **Rotproof Non-Fray Carpet black.** 2mtr (78 $\frac{3}{4}$ ") wide. Closely woven short pile, approx. 5mm ($\frac{3}{16}$ ") thick. Polypropylene carpet, non-fray type with synthetic backing. Please allow for carriage due to width of roll Per mtr
- 154a **'Thin-Ribbed' Carpet.** Rotproof polypropylene. 2mtr (78 $\frac{3}{4}$ ") wide. Non-fray. Narrow 3mm ($\frac{1}{8}$ ") ribs running for length of the roll. Thin and pliable, so needs a good underfelt to give it some 'body'. Stocked in light beige, mid grey, black, light grey and brown Per mtr
154a carpet is ideal for side and roof linings on campers and van conversions.
- 61 **Karvel Carpet.** 150cm (59") wide. Newly produced tight polypropylene pile with discreet 'ribbed' effect as original. Hessian backing makes Karvel virtually non-fraying, ribs run across roll. Stocked in black, dark blue and red Per mtr
- 441 **'Wilton' Type Carpet.** 1.5mtr (59") wide. A good quality 80% wool deep pile 'Wilton' type carpet, latex rubber backed. The natural spring in the wool gives it a luxurious feel. Available in beige, black, grey, red, blue and green. A good width for a wool carpet which may allow for less joins Per mtr

CARPET SUNDRIES/ACCESSORIES

- 59 **Carpet Fastener Socket.** Black metal ring is pushed down through the pile into the socket and the points folded over. Invisible when carpet is in position .. Pkt 10
- 60 **Carpet Fastener Stud.** For fitting to floorboards or side panels with screw. The other part of No. 59 Pkt 10

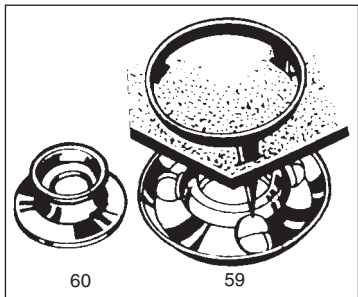

- 278 **Storvic Heel Pad.** Tough, pliable PVC. Approx. 1mm thick. Original classic car heel-mat material. Black, red, navy, beige and grey. For sewing into high-wear areas of the carpet.
Per piece approx. 28cm x 18cm (11" x 7") Each
Per mtr off the roll, widths vary please enquire Per mtr
- 234 **Carpet Binding.** 38mm (1 $\frac{1}{2}$ ") wide cotton webbing in black and beige Per mtr
- 246 **Carpet Binding.** 38mm (1 $\frac{1}{2}$ ") wide non-stretch leathercloth. One side folded over for neat top edge. Available in dark blue, black, brown, biscuit, cream, doeskin, green, grey, mulberry and red. Per mtr

GASKET MATERIALS

70R	Rubberised cork sheet 1.5mm (1/16") approx. 3' x 2'	Each
71R	Rubberised cork sheet 3mm (1/8") x approx. 3' x 2'	Each
72	Paper jointing 0.4mm (1/64") x approx. 3' x 2'	Each
73	Paper jointing 0.80mm (1/32") x approx. 3' x 2'	Each
75	Asbestos free graphited sheet 0.75mm (1/32") x approx. 2' x 1' ..	Each
76	Asbestos free graphited sheet 1.5mm (1/16") x approx. 2' x 1' ..	Each

WINDOW CHANNELS

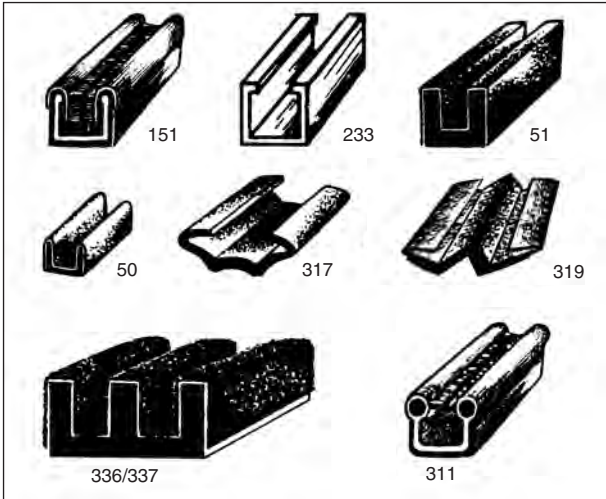

- 151 Window Channel.** Single track flexible metal covered in felt/rubber. Can take 4.7mm or 6mm (3/16" or 1/4") glass. Approx. 14mm (9/16") overall width. This channel will hold its shape when bent. Can be coiled for posting Per mtr
- 151R Rigid Single Track Window Channel.** 14mm (9/16") overall width. Same as 151 but TOTALLY RIGID Per 2mtr (78 3/4") length
- 51 Window Channel.** Single track velvet covered rubber for 6mm (1/4") glass. Approx. 13mm (1/2") overall width Per mtr
- 50 Window Channel.** Single track velvet covered rubber for 4.7mm (3/16") glass. Approx. 10mm (3/8") wide, so our SMALLEST channel! Per mtr
- 317 Universal Window Channel.** Single track velvet covered rubber. Approx. 12mm (1/2") overall at base, but sides have natural tendency to 'lean-out', making it very adaptable. Inner flanges can cope with varying thicknesses of glass Per mtr
- 319 Universal Window Channel.** Larger version of 317. Approx. 16mm (5/8") overall width at base. Sides 'lean-out' and inner flanges cope with varying thicknesses of glass Per mtr
- 311 Stainless Bead Channel.** 16mm wide (5/8") Semi rigid metal channel with stainless steel beading. Rubber coated and lined with felt and plush material. As used on Morris Traveller sliding side windows, Rovers and similar. Per 1.4mtr (55") length
- 337 Double Velvet Covered Rubber Window Channel.** For 6mm (1/4") glass. Overall width 22mm (7/8") Per mtr
- 336 Double Velvet Covered Rubber Window Channel.** For 4.7mm (3/16") glass. Overall width 20.5mm (approx. 13/16") Per mtr
- 116 Special Window Channel for 233.** Single track velvet covered rubber for 4.7mm (3/16") glass to fit snugly into 233 rigid alloy. (NOT shown) Per mtr
- 117 Special Window Channel for 233.** Single track velvet covered rubber for 6mm (1/4") glass to fit snugly into 233 rigid alloy. (NOT shown) Per mtr

BLACK VELVET AND BLACK FELT

- 378 **Thin Black Velvet Fabric.** 1.38m (54 $\frac{1}{4}$ " wide. Ideal for re-covering window channels or horizontal weatherstrip on early vehicles ie wrapped around R181 or R97 black rubbers on p18 (useful for surfaces adjacent to glass where non friction is preferable... even glove box lining).
Per 10cm (4") wide strip \times 1.37mtr (54") long Each
Per mtr off the roll 1.37mtr (54") wide Per mtr
- 87 **Black Felt** for window channels or fitting between bodywork and chassis. Specify size when ordering:
25mm \times 3mm (1" \times $\frac{1}{8}$ ") Per 1.83mtr (6ft) length
50mm \times 1.5mm (2" \times $\frac{1}{16}$ ") Per 1.83mtr (6ft) length
50mm \times 3mm (2" \times $\frac{1}{8}$ ") Per 1.83mtr (6ft) length
50mm \times 6mm (2" \times $\frac{1}{4}$ ") Per 1.83mtr (6ft) length
75mm \times 3mm (3" \times $\frac{1}{8}$ ") Per 1.83mtr (6ft) length
75mm \times 6mm (3" \times $\frac{1}{4}$ ") Per 1.83mtr (6ft) length
Bulk Black Felt 3mm ($\frac{1}{8}$ ") thick from roll approx. 183cm (72") wide for lining tool boxes etc Per approx. square 30.5cm (1ft) Per 25cm off the roll

WINDOW WEATHERSTRIP

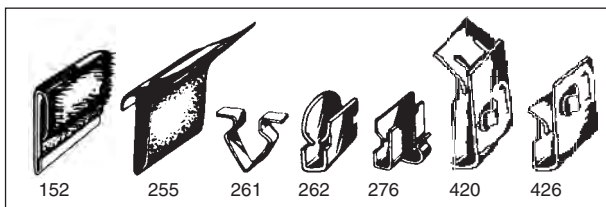

- 255 **Window Weatherstrip.** This is the exterior waistseal in rubber with PVC vertical insert. Black velvet covering on inner face that fits against the glass. Would seal up to 11mm ($\frac{7}{16}$ ") gap between glass and window frame, but minimum 6mm ($\frac{1}{4}$ ") gap unless the leading edge is trimmed down. Per 1mtr (39 $\frac{1}{4}$ ") length Per length
- 95a **Window Weatherstrip.** Small exterior weatherstrip in rubber with PVC vertical insert. Black velvet covering on inner face that fits against the glass. Seals up to 10mm ($\frac{3}{8}$ ") gap. Useful where space is limited. 15mm across top of "T". Leg is approx. 10mm long. A smaller alternative to the 255 weatherstrip above (NOT SHOWN).
Per 1mtr (39 $\frac{1}{4}$ ") length Per length
- 152 **Window Weatherstrip.** 15mm ($\frac{9}{16}$ ") tall. Metal insert. One side covered in plush material that rubs against the glass. Both interior and exterior use. Please advise if weatherstrip can be cut down for posting. Per 2mtr (78 $\frac{3}{4}$ ") length Per length
- 152a **Window Weatherstrip.** 11.5mm ($\frac{7}{16}$ ") tall. Approx 6mm thick ($\frac{1}{4}$ ") Metal insert. One side covered in plush material. A smaller alternative to the 152. (NOT SHOWN) Per 2mtr (78 $\frac{3}{4}$ ") length
- 261 **Spring Clip** for 152. The weatherstrip must be drilled to accept this clip (as used on Morris Minors) Pkt 10
- 276 **Spring Clip** that fits onto the bottom bead of 152 weatherstrip (as used on Jaguar MkII saloons and similar) Pkt 10
- 262 **'U' Spring Clip** with 4.7mm ($\frac{3}{16}$ ") gap. Can be used with 255 weatherstrip Pkt 10
- 420 **Ford Spring Clip.** External weatherstrip clip. Long 'U' section pushes onto metal edge of door and small 'u' set at 90° holds the weatherstrip Pkt 10
- 426 **Weatherstrip Clip.** Long "U" section pushes onto metal edge of door and small "u" set at 90° holds the weatherstrip. Widely used by Fords as an internal weatherstrip clip Pkt 10

For all the latest product information and secure on-line ordering visit our website www.woolies-trim.co.uk

300 Self-Adhesive Black Sponge Strip. Skinned on 2 SIDES ONLY, but closed-cell and virtually non-absorbent (technically only 5% absorbent). Special blend of synthetic polymers, giving good resistance to weather ageing and oil contamination. Self-extinguishing when the source of ignition is removed. Surface must be CLEAN and DRY before applying with finger pressure.

The drawings below show the basic widths and thicknesses available, providing a useful range of 22 different sizes.



For Self-Adhesive Black Sponge SHEET 3mm (1/8") and 8mm (5/16") thick refer to 300s on page 19.

- 3mm x 13mm (1/8" x 1/2") Per mtr
- 3mm x 25mm (1/8" x 1") Per mtr
- 3mm x 38mm (1/8" x 1 1/2") Per mtr
- 3mm x 50mm (1/8" x 2") Per mtr
- 3mm x 75mm (1/8" x 3") Per mtr

} Per approx. 30mtr (98ft) rolls LESS Special 15% Trade Discount

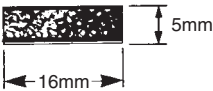

- 5mm x 16mm (3/16" x 5/8") Per mtr

} Per approx. 30mtr (98ft) rolls LESS Special 15% Trade Discount

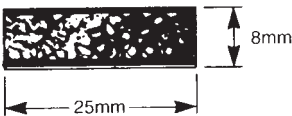

- 8mm x 25mm (5/16" x 1") Per mtr
- 8mm x 38mm (5/16" x 1 1/2") Per mtr
- 8mm x 50mm (5/16" x 2") Per mtr
- 8mm x 75mm (5/16" x 3") Per mtr

} Per approx. 20mtr (65ft) rolls LESS Special 15% Trade Discount

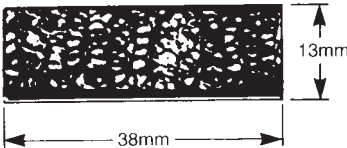

- 13mm x 25mm (1/2" x 1") Per mtr
- 13mm x 38mm (1/2" x 1 1/2") Per mtr
- 13mm x 50mm (1/2" x 2") Per mtr
- 13mm x 75mm (1/2" x 3") Per mtr

} Per approx. 14mtr (45ft) rolls LESS Special 15% Trade Discount

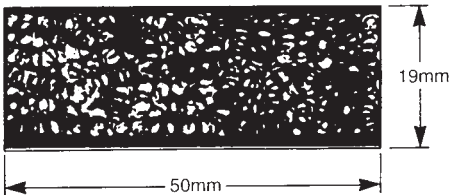

- 19mm x 25mm (3/4" x 1") Per mtr
- 19mm x 38mm (3/4" x 1 1/2") Per mtr
- 19mm x 50mm (3/4" x 2") Per mtr
- 19mm x 75mm (3/4" x 3") Per mtr

} Per approx. 10mtr (32ft) rolls LESS Special 15% Trade Discount

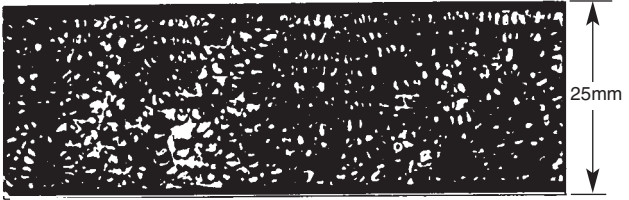

75mm

25mm × 25mm (1" × 1") Per mtr
 25mm × 38mm (1" × 1½") Per mtr
 25mm × 50mm (1" × 2") Per mtr
 25mm × 75mm (1" × 3") Per mtr

Per approx. 8mtr (26ft)
 rolls LESS Special 15%
 Trade Discount

Black Neoprene Sponge Extrusions (shown approx. life size)

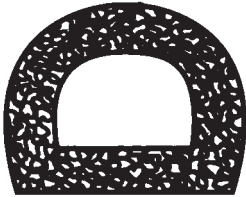

SRS 8



SRS 25



SRS 20



SRS 30



SRS 15



SRS 91



SRS 26



SRS 24*

*fits 68 alloy
 tread on p22



SRS 27



SRS 2



SRS 97



SRS 5



SRS 4



SRS 36



SRS 110



SRS 71



SRS 14



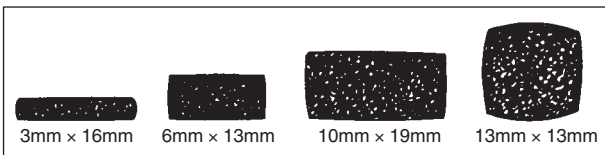

160 Moulded Sponge Strip (Skinned on all 4 sides).

3mm x 16mm (1/8" x 5/8")	Per mtr
6mm x 13mm (1/4" x 1/2")	Per mtr
13mm x 13mm (1/2" x 1/2")	Per mtr
10mm x 19mm (3/8" x 3/4")	Per mtr

Skinned Sponge Extrusions (shown approx. life size)

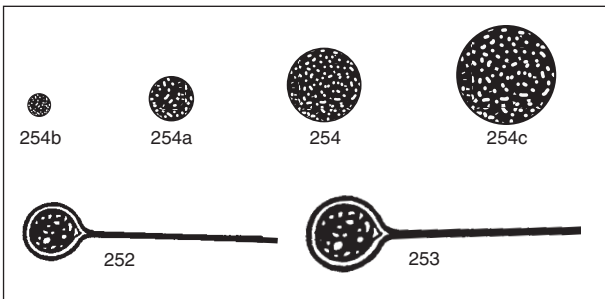

254b Neoprene Sponge Cord 3mm (1/8") dia.	Per mtr
254a Neoprene Sponge Cord 6mm (1/4") dia.	Per mtr
254 Neoprene Sponge Cord 10mm (3/8") dia., ideal for making draught excluder piping	Per mtr
254c Neoprene Sponge Cord 13mm (1/2") dia.	Per mtr
252 Sponge Piping 6mm (1/4") sponge cord wrapped in black rubberised fabric. Approx 25mm (1") flange	Per mtr
253 Sponge Piping 8mm (5/16") dia. x 30mm (1 3/16") flange	Per mtr



427 Self Adhesive Bead with Lip. Approx. 16mm (5/8") tall. Foot approx. 11mm (7/16") wide	Per mtr
363 Hollow Self Adhesive 'D' Sponge. Very collapsible. Please note extra adhesive may need to be applied Approx. 13mm (1/2") wide	Per mtr

Black Rubber/PVC Extrusions (shown approx. life size)

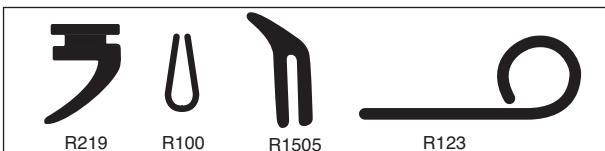

Black Rubber Extrusions from Stock

The following are shown as **APPROX. LIFE SIZE END SECTIONS**.

PRICES PER METRE unless stated otherwise. We are always prepared to accept customer's samples and will give a quick and positive answer as to availability.

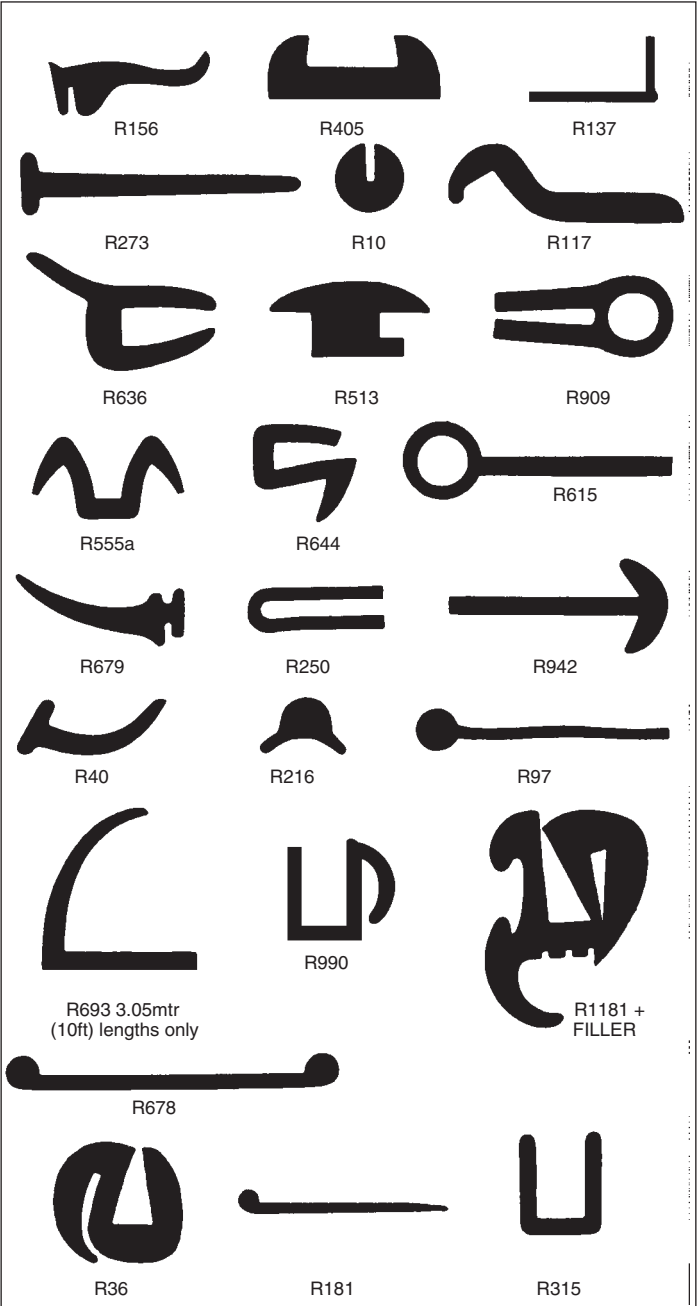

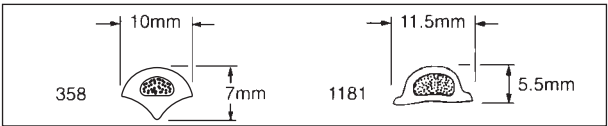
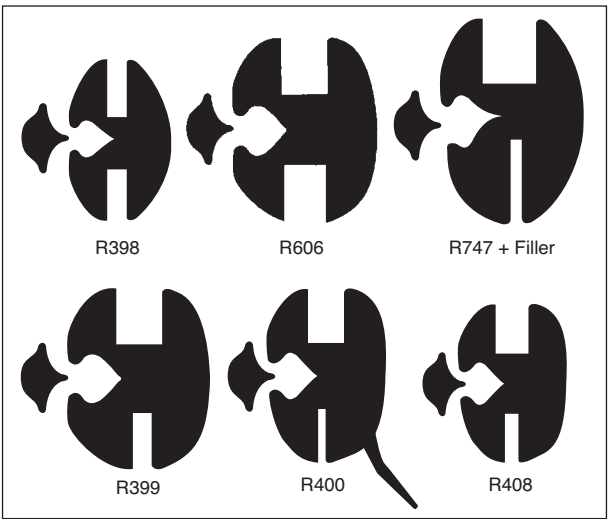

- 358 **Plastic 'Chrome' Filler Insert.** An alternative to the black filler supplied with the sections shown above Per mtr
- 1181 **Plastic 'Chrome' Filler Insert,** as supplied with R1181 shown on page 18 Per mtr

SURFACE PREPARATION FOR STICKING RUBBER AND SPONGE EXTRUSIONS. All adhesives work best on a clean dry surface. We suggest that the 'sticking surface' should be nominally roughed-up with a fine abrasive paper to ensure a good key.

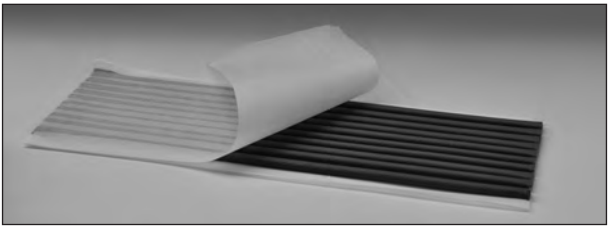

- 434 **Body Caulking.** For sealing wherever it is necessary to prevent the passage of air and moisture between metal, wood, glass and plastic. Surfaces must be well cleaned. Product is non-hardening, will not shrink, is waterproof and can be painted. Dark grey in colour.
 Per pack of 10 strips, 6mm x 300mm (approx 1/4" x 12") Each
 Per box of 60 strips, 6mm x 300mm (approx 1/4" x 12") Each
- 385 **Flat Black Neoprene Rubber SHEET** 1.36mtr (53 1/2") wide smooth finish.
 1.5mm (1/16") thick Per mtr
 3mm (1/8") thick Per mtr
 6mm (1/4") thick Per mtr
- 300S **Self Adhesive Black Sponge SHEET** 1mtr (39 3/8") wide. Skinned on 2 sides but closed-cell and virtually non-absorbent (refer p15 and 16 for full details + 22 different sizes of STRIP). Take care when peeling off backing, only peel backing and not sticky layer as well.
 3mm (1/8") thick Per mtr
 8mm (5/16") thick Per mtr

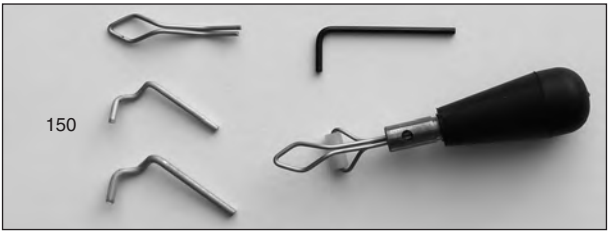

150 **Universal Fitting Tool.** For filler inserts in windscreen sections on page 19. Good, grippable synthetic rubber handle. Supplied with a selection of detachable tools as shown..... Per set

RUBBER TUBING, MATTING & SHEET

- 301 **Hollow Rubber Drain Tubing.** Best quality black rubber. All sizes have 3mm (1/8") thick walls. Also useful as a 'core' for large draught excluder piping:
 - 6mm (1/4") bore 13mm (1/2") OUTSIDE dia. Per mtr
 - 8mm (5/16") bore 15mm (9/16") OUTSIDE dia. Per mtr
 - 10mm (3/8") bore 16mm (5/8") OUTSIDE dia. Per mtr
 - 13mm (1/2") bore 19mm (3/4") OUTSIDE dia. Per mtr
- 372 **Hollow Rubber Tubing.** 8mm (5/16") OUTSIDE dia. with 4.7mm (3/16") hole. Useful as a small drain tube or 'inner' for pipings Per mtr
- 281 **Loctite Super Glue.** Ideal for our rubber/sponge extrusions onto metal, painted surfaces, wood, plus some fabrics and plastics. (NOT glass.) Gives a good bond in seconds, with full strength after approx. 6 hours. Apply SPARINGLY to one surface only. Careful use could give up to 120-152cm (4-5ft) run per 1 gram of glue
 - Per 3grm tube
 - Per 5grm bottle



- 85 **Black Rubber Sheet.** Broad rib. 4 flat-topped ribs per 25mm (1").
 - Per running mtr x 30cm (11 3/4") wide
 - Per running mtr x 60cm (23 1/2") wide
 - Per running mtr x 90cm (35 1/2") wide
 - Per running mtr x 120cm (47 1/2") wide
- 86 **Black Rubber Sheet.** Narrow rib. 8 point-topped ribs per 25mm (1").
 - Per running mtr x 30cm (11 3/4") wide
 - Per running mtr x 60cm (23 1/2") wide
 - Per running mtr x 90cm (35 1/2") wide
 - Per running mtr x 120cm (47 1/2") wide

Both ribbed mattings are supplied to us in 10mtr rolls x 120cm wide (approx. 33ft x 4ft) with ribs running along the roll. Please enquire for full roll Trade discount.

- 104 **Black Pyramid Pattern Matting.** Neoprene/Rubber. Approx. 3mm (1/8") thick. Pyramids are diagonal along the roll (DIAMOND shaped), giving 4 per 25mm (1"). Rolls approx. 32mtr (105ft) long and 915mm (3ft) wide
 - Per running mtr x 30.5cm (1ft) wide
 - Per running mtr x 61cm (2ft) wide
 - Per running mtr x 91.5cm (3ft) wide
- 386 **HEAVY Black Pyramid Pattern Matting.** 6mm (1/4") thick. Pyramids are SQUARE along the roll, giving approx. 4 per 25mm (1"). Per mtr Supplied to NEAREST 33cm (13") x 1.2mtr widePrice *pro rata*
- 88 **Flat Black Rubber Strip** for glazing or packing:
 - 50mm x 0.8mm (2" x 1/32") Per mtr
 - 50mm x 1.5mm (2" x 1/16") Per mtr
 - 50mm x 3mm (2" x 1/8") Per mtr
 - 75mm x 1.5mm (3" x 1/16") Per mtr
 - 75mm x 3mm (3" x 1/8") Per mtr

PIPING

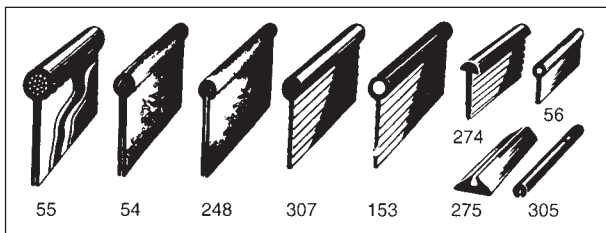

- 274 **Wing Piping, PVC.** Half round 'T' section. 6mm (1/4") wide bead with ribbed flange 16mm (5/8") long. Ex-stock in black and white Per mtr
- 307 **Solid Bead Wing Piping.** Approx. 6mm (1/4") dia. bead with 25mm (1") flange. Ex-stock in standard Morris Minor colours: Trafalgar Blue, Standard Grey, Smoke Grey (light blue), Almond Green, Old English White, Black, Red and Maroon Per mtr
We can offer particularly good Trade discount when purchasing full rolls of 307 at approx. 60mtr.
- 153 **Wing Piping, PVC.** Hollow bead 6mm (1/4") dia. with 25mm (1") flange. Stocked in black only Per mtr
- 55 **Wing Piping.** Shiny patent finish black leathercloth 8mm (5/16") cord with 32mm (1 1/4") flange Per mtr
- 54a **Wing Piping.** Grained dull black leathercloth 8mm (5/16") dia. cord with 32mm (1 1/4") flange Per mtr
- 54 **Wing Piping.** Grained dull black leathercloth 6mm (1/4") dia. cord with 32mm (1 1/4") flange Per mtr
- 248 **Wing Piping.** As 54 but 4.7mm (3/16") dia. cord Per mtr
- 56 **Interior Piping, PVC.** 3mm (1/8") dia. bead. 10mm (3/8") flange. Ex-stock in black, red, white, grey, yellow, brown and blue Per mtr
- 29 **Piping cord.** 3mm (1/8") dia. For seat piping or making hidem ie. can be covered with headlining material or thin leathercloth Per mtr
- 210 **Interior Piping Vinyl Covered.** Approx. 4mm (5/32") dia. bead. 10mm (3/8") flange. A good range of colours Per mtr
- 275 **Bumper Override Beading, PVC.** 10mm (3/8") wide. 1.5mm (1/16") slot. Black Per mtr
- 305 **Miniature Black PVC Override.** Only 4.7mm (3/16") dia Per mtr

ALUMINIUM STRIP

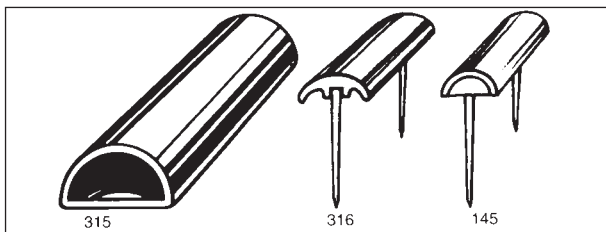

- 315 **Hollow 'D' Section Steel Bar for Hood Frames.** 19mm (3/4") wide and 10mm (3/8") tall. Stocked in approx. 183cm (6ft) lengths. Needs a pipe-bender to get a professional, constant radius bend Per length
- 316 **Soft Alloy Pin Beading.** Really workable. Highly polished finish. Choice of 10mm or 12mm (3/8" or approx. 1/2") wide. Approx. 2.5mtr (98 1/2") lengths. 16mm (5/8") long nails positioned every 90-100mm approx. (3 3/4"-4") Per 2.5 metre length 10mm wide
 Per 2.5 metre length 12mm wide
- 145 **Brass Pin Beading.** 11mm (7/16") wide. Half round lead-filled brass beading. 16mm (5/8") nails approx every 100mm (4"). Can be covered with leathercloth or leather, plated or polished to self colour Per 2 metre length

Please allow for carriage when ordering the above lengths.

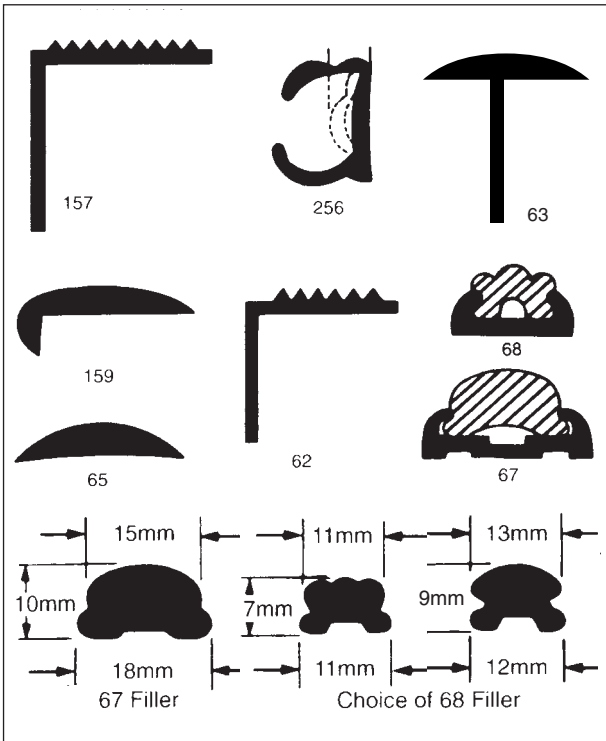

- 256 Guttering. Lip folds down to hide screw heads Per 2.13mtr (7ft)
- 62 Running board edging. 6 rib fluted top. 19mm sides (3/4")
..... Per 2mtr (6 1/2ft)
- 157 Running board edging. 9 rib fluted top. 25mm sides (1")
..... Per 2mtr (6 1/2ft)
- 63 Offset tee. 22mm (7/8") wide. 19mm (3/4") flange Per 2mtr (6 1/2ft)
- 65 Half round 19mm (3/4") wide (shown oversize) Per 5mtr (16.4ft)
- 66 Half round 16mm (5/8") wide Per 4mtr (13ft)
- 158 Half round 13mm (1/2") wide Per 4mtr (13ft)
- 159 Cope moulding 24mm (1 5/16") wide overall. 20mm x 6mm inside
..... Per 2mtr (6 1/2ft)

Aluminium Running Board Tread with Black Rubber Filler

- 67 22mm (7/8") wide tread complete with domed filler .. Per 1.83mtr (6ft)
 - 68 16mm (5/8") wide. Domed or 3-rib filler as shown.... Per 1.83mtr (6ft)
- (Other profiles can be used with 68 tread: SRS24 (pg16) is a **tight** fit.
Rubber filler available SEPARATELY: Large domed as 67... Per mtr
Small domed as 68 .. Per mtr
3-rib as 68 Per mtr

Aluminium also available SEPARATELY without filler:

- 67 aluminium only Per 1.83mtr (6ft)
- 68 aluminium only Per 1.83mtr (6ft)

Please allow for carriage or arrange collection of all aluminium strips.
Alternatively, we can cut items down to 1.45mtr long or less for posting.



Federation of British Historic Vehicle Clubs

We are pleased to be members of the Trade Support Scheme of the FBHVC, who strive to "ensure that club members and their vehicles continue to enjoy the freedom of the use of the roads in the United Kingdom and Europe".

SCREWS AND BONNET TAPE



- 297 Dished Cup Washers.** Nickel on brass. For counter-sunk screws to give that finishing touch on trim and interior cappings.
- | | | |
|------------------------------|--------------|-------------------|
| Size 4 (overall dia. 7mm) | Pkt 10 | Per box 200 |
| Size 6 (overall dia. 8.5mm) | Pkt 10 | Per box 200 |
| Size 8 (overall dia. 10.5mm) | Pkt 10 | Per box 200 |
- 43 Raised Cup Washers.** Nickel on brass.
- | | | |
|----------------------------|--------------|-------------------|
| Size 4 (overall dia. 8mm) | Pkt 10 | Per box 200 |
| Size 6 (overall dia. 10mm) | Pkt 10 | Per box 200 |
| Size 8 (overall dia. 12mm) | Pkt 10 | Per box 200 |
- 293 Captive Nut.** Tempered steel. For push-fit onto edge of panel or similar. Suitable for size 6 and 8 screws only Pkt 10
- 298 Double Sided Edge Clip.** Tempered steel. 11mm tall. 1.3mm gaps Pkt 10
- 299 Self Tapping Countersunk Raised Slot-head Screws.** Stainless steel. Dia. of screw head: 4 = 5.5mm, 6 = 6.5mm and 8 = 8mm.
- | | | |
|------------------------|--------------|-------------------|
| 1/2" (13mm) x size 4 | Pkt 10 | Per box 200 |
| 5/8" (16mm) x size 4 | Pkt 10 | Per box 200 |
| 3/4" (19mm) x size 4 | Pkt 10 | Per box 200 |
| 1" (25mm) x size 4 | Pkt 10 | Per box 200 |
| 1/2" (13mm) x size 6 | Pkt 10 | Per box 200 |
| 5/8" (16mm) x size 6 | Pkt 10 | Per box 200 |
| 3/4" (19mm) x size 6 | Pkt 10 | Per box 200 |
| 1" (25mm) x size 6 | Pkt 10 | Per box 200 |
| 1 1/4" (32mm) x size 6 | Pkt 10 | Per box 200 |
| 5/8" (16mm) x size 8 | Pkt 10 | Per box 200 |
| 3/4" (19mm) x size 8 | Pkt 10 | Per box 200 |
| 1" (25mm) x size 8 | Pkt 10 | Per box 200 |
| 1 1/4" (32mm) x size 8 | Pkt 10 | Per box 200 |
- 44 Wood Screws.** Raised slot-head countersunk woodscrews nickel on brass. Dia. of screw head: 4 = 5.5mm, 6 = 6.5mm and 8 = 8mm.
- | | | |
|------------------------|--------------|-------------------|
| 5/8" (16mm) x size 4 | Pkt 10 | Per box 200 |
| 3/4" (19mm) x size 4 | Pkt 10 | Per box 200 |
| 1/2" (13mm) x size 6 | Pkt 10 | Per box 200 |
| 3/4" (19mm) x size 6 | Pkt 10 | Per box 200 |
| 1 1/4" (32mm) x size 6 | Pkt 10 | Per box 200 |
| 3/4" (19mm) x size 8 | Pkt 10 | Per box 200 |
| 1 1/4" (32mm) x size 8 | Pkt 10 | Per box 200 |

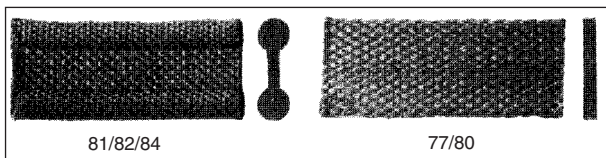

Bonnet Tape

Woven FLAT type for threading through holes in radiator or bulkhead.

- | | | |
|----|------------------|---------------|
| 77 | 10mm (3/8") wide | Per mtr |
| 78 | 13mm (1/2") wide | Per mtr |
| 79 | 16mm (5/8") wide | Per mtr |
| 80 | 22mm (7/8") wide | Per mtr |
- Woven DOUBLE BEADED type for riveting.

- | | | |
|----|------------------|---------------|
| 81 | 16mm (5/8") wide | Per mtr |
| 82 | 22mm (7/8") wide | Per mtr |
| 84 | 19mm (3/4") wide | Per mtr |

- 184 Bifurcated Brass Plated Rivets.** 8mm (5/16") heads. 3mm shoulder then 13mm (1/2") legs. Suit 81 and 82 above Pkt 10

LOCKS AND HANDLES

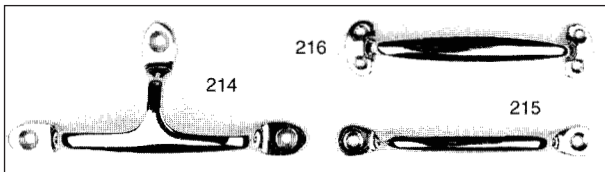

- 216 **Grab Handle.** Chrome on brass. 4 screw mounting. Hole centres 102mm (4") Each
- 215 **Grab Handle.** Chrome on brass. 2 screw mounting. Hole centres 102mm (4"), but may vary slightly. Please enquire. Each
- 214 **Bonnet Handle.** Chrome on brass. 3-legged to 'spread the load'. Horizontal hole centres 120mm (4¾") and diagonally approx. 75mm (3") Each
- All three handles above are sometimes available in unplated state as **POLISHED BRASS**. Please enquire.



- 69 **Competition Bonnet/Boot Pins.** Patented stainless steel base-plate, pin guide and finger ring. Positive, sliding over-centre action for rapid and positive location. Solid mounting pillar approx. 11mm (7/16") dia. 127mm (5") tall and threaded for 95mm (3¾"). As used by leading competition teams Per pair
- 346 **Bonnet/Panel Lock.** Chrome bezel 25mm (1") dia. Threaded body 19mm (¾") long, fits into 19mm (¾") dia. hole. Supplied with 2 removable keys Each

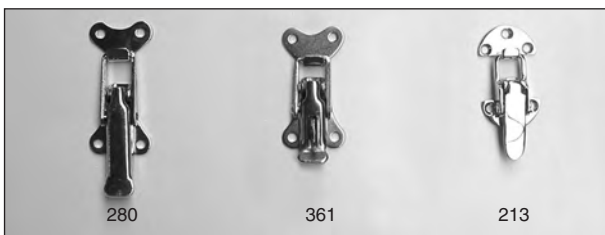

- 280 **Over Centre Catch.** Chrome on steel. Overall 89mm (3½") tall as shown Each
- 361 **Over Centre Catch.** Chrome on steel. Overall 73mm (2⅞") tall as shown. With extra lug for securing with a padlock Each
- 213 **Over Centre Catch.** Chrome on brass. 75mm (3") long. 32mm (1¼") wide Each
- Items 209, 211 and 213 are sometimes available in unplated state as **POLISHED BRASS**. Please enquire.

For all the latest product information and secure on-line ordering visit our website www.woolies-trim.co.uk



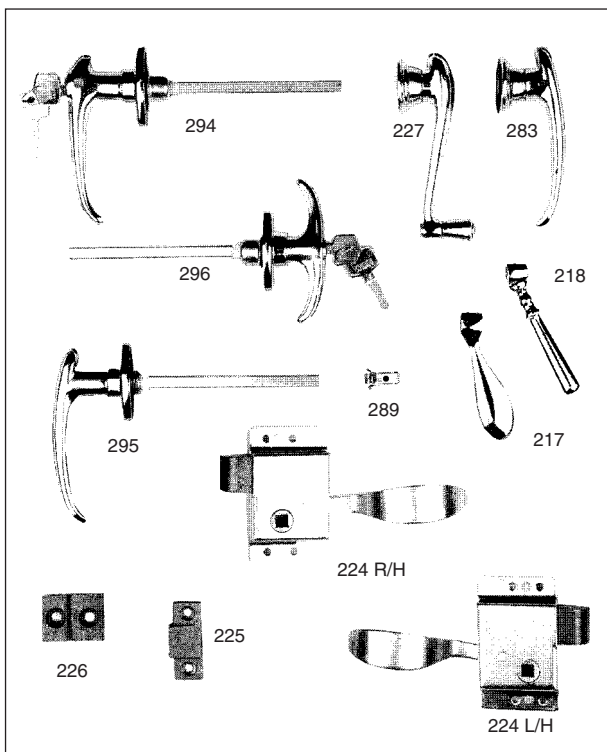

- 294 **Locking Exterior Handle.** Chrome 108mm (4¼") long. Mounting hole centre 37mm (1½"). 8mm (5/16") square steel shaft 127mm (5") long that can be cut down to size. Raised rib design Each
- 295 **Non-Locking Exterior Handle.** Chrome. To match No. 294 above Each
- 296 **Locking Boot Handle.** Chrome 95mm (3¾") long. Mounting hole centres 37mm (1½"). 8mm (5/16") square shaft that can be cut to size Each
- 227 **Window Winder.** Chrome. 120mm (4¾") long. Spring loaded escutcheon. Raised rib design to complement 294/5. Will need 289 to fit snugly onto the 8mm (5/16") shaft Each
- 283 **Interior Handle.** Chrome. 115mm (4½") long. Matches the 227 winder. Spring loaded escutcheon. Will need 289 to fit snugly onto the 8mm (5/16") square shaft Each
- 395 **Spring loaded escutcheon.** For 227 and 283 supplied separately.. Each
- 289 **Spring Steel Adaptor.** Converts the 10mm (3/8") hole in 227 and 283 to accept an 8mm (5/16") square shaft, as on the exterior handles 294/5/6 above Each
- 224 **Door Lock.** Zinc plated finish. Body 87mm x 50mm (3 7/16" x 2"). Long tongue. Shaped handle 89mm (3½") long. Handed Each
- 225 **Single Striker Plate.** 50mm x 22mm (2" x 7/8"). Cast Each
- 226 **Double Striker Plate.** 30mm x 38mm (1 3/16" x 1½"). Cast Each
- 218 **Interior Handle.** VDP type solid brass casting chrome plated. Approx. 95mm long (3¾") to fit 8mm (5/16") shaft at 90° angle Each
- 217 **Interior Handle.** Vintage type chrome on brass. Approx. 82mm (3¼") long to fit 8mm (5/16") shaft at 45° angle Each

For all the latest product information and secure on-line ordering visit our website www.woolies-trim.co.uk



- 211 **Bonnet Catch.** Chrome on brass. 140mm (5½") long as shown with approx. 6mm (¼") of spring lift. Heavier than 209 with stronger tension. Ideal for larger bonnets. Complete with catch plate as shown Each
- 209 **Bonnet Catch.** Chrome on brass. 108mm (4¼") long as shown with approx. 13mm (½") of spring lift. Rubber buffer mounted on the rear of the barrel. Complete with catch plate as shown Each
- 414 **Rubber Bonnet Catches.** 127mm (5") overall length. Complete with catch plate as shown Per pair
- 345 **Bonnet Catch.** Exposed-spring type in stainless steel. 127mm (5") overall length. Complete with catch plate as shown Per pair

ACCESSORIES

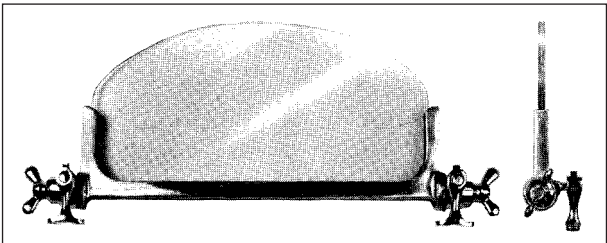

- 83 **Aeroscreen.** This is the Brooklands pattern aeroscreen fitted with Triplex laminated glass suitable for RAC competition. Polished aluminium frame with chrome fittings and mounting legs. Mounting spigots are offset allowing variable distance between bodywork and the bottom of the screen. Frame width 305mm (12") and overall width 406mm (16") Each



- 318 **Badge Bar** Complete with 4 clips. Chrome-on-brass legs, clips and end caps. Slightly cranked stainless steel bar as shown. Bar is 19mm (¾") dia and 559mm (22") overall length. Per bar with 4 clips Each
- 110 **Badge Bar Clips** Chrome-on-brass for 19mm bar (¾") as above. Extra clips can be purchased separately..... Each



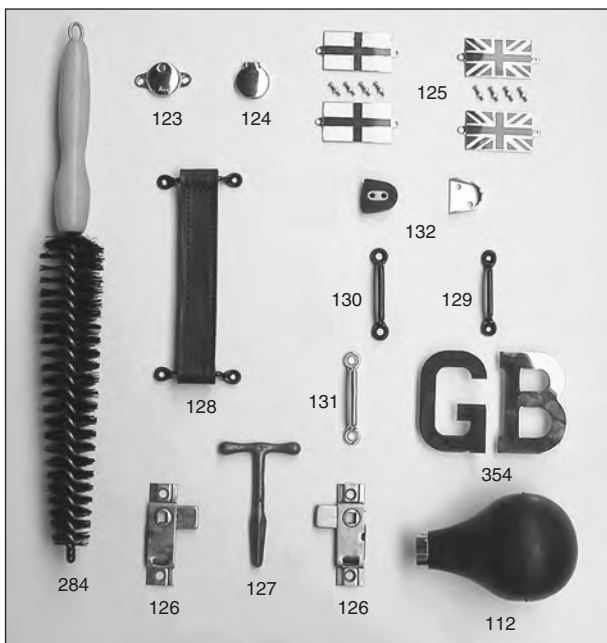

- 284 **Spoke Cleaning Brushes** 430mm (17") long. Flexible wire core. Wooden handle. Choice of SOFT or HEAVY bristle Each
- 123 **Key Hole Cover.** Chrome on brass. Top swings to one side and is spring loaded. Mounting hole centres 38mm (1½") Each
- 124 **Key Hole Cover.** Chrome. Spring loaded lift-up-top hides screw holes. Mounting hole centres 20.5mm (13/16") Each
- 125 **Enamel Union Jacks.** Well made in jeweller's enamel. Chrome. 57mm x 35mm (2¼" x 1¾). Supplied in pairs complete with fixing screws Per pair
- 125a **St George Cross.** Well made in jeweller's enamel. Chrome. 57mm x 35mm (2¼" x 1¾). Supplied in pairs complete with fixing screws Per pair
- 126 **Budget Locks.** All steel. Left and right handed. Mounting hole centres 67mm (25/8") Each
- 425 **Budget Lock Striker Plate.** Zinc plated steel. Use in conjunction with the 126 budget locks. Overall size 13mm x 76mm (11/16" x 3"). Countersunk hole centres 60mm (23/8"). Slot size 6mm x 44mm (¼" x 1¾") (not shown) Each
- 127 **Carriage Key.** Tapered square shaft to suit above budget lock. 100mm (4") tall. Unplated Each
- 128 **Door Check Straps.** Brown leather approx. 178mm (7") long with black enamel staples Each
- 129 **Staples.** Black on steel for 32mm (1¼") wide strapping Each
- 130 **Staples.** Black on steel for 38mm (1½") wide strapping Each
- 130a **Staples.** BRASS for 38mm (1½") wide strapping Each
- 131 **Staples.** Chrome on brass for 38mm (1½") wide strapping Each
- 132 **Door Buffers.** 'D' shaped 29mm (11/8") long x 13mm (½") thick complete with zinc plated shoe and brass eyelet Each
- 112 **Horn Bulb** 82mm (3¼") approx. dia. A good medium sized bulb that will suit any straight or bugle-type horn. Made in synthetic rubber to give a good firm feel. Complete with chrome ferrule. Hole 14mm (9/16") dia. Each
- 354 **'GB' Letters in Chrome.** Separate 'GB' letters 84mm (35/16") tall chrome-on-brass. Integral threaded mounting studs/nuts on the back of each letter Per set 'GB'

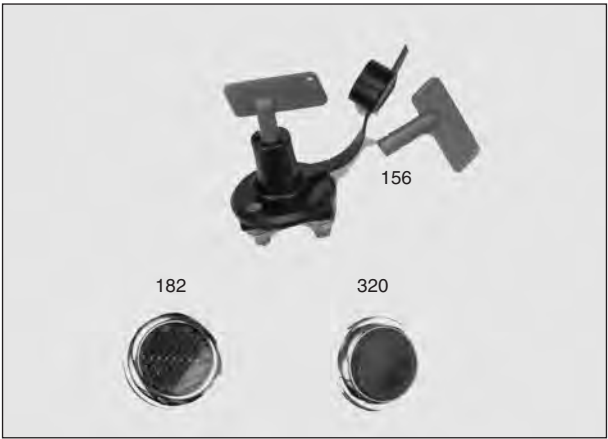

- 156 **Battery Master Switch.** A very basic switch with detachable red plastic key, as shown. 2 hole mounting through the body with hole centres approx. 41mm (1⁵/₈"). Controls circuits of up to 300 amps at 12 or 24 volts. To switch off and isolate circuit, turn anti-clockwise and remove key Each
- 182 **Lucas Chrome Reflector.** Spun brass rim. Rubber base. Screw fitting. 50mm (2") dia. Can be stripped to polished brass Each
- 320 **Chrome Reflector.** 50mm (2") dia. Brass rim. Self tapping screw fitting Each
- 320b As 320 in brass (not shown) Each



- 312 **Period Goggles** with double glazed lenses to prevent misting. Laminated, angled lenses made in high impact-resisting material. Adjustable nosebridge, detachable strap and comfortable padded surround in dark brown expanded vinyl. Aluminium coloured frames Each
 - 279 **Period Goggles.** BLACK all-leather surrounds and CHROME plated frames. Our best quality goggles Each
- N.B: ALL GOGGLES NOT SUITABLE FOR USE WITH SPECTACLES.**



Federation of British Historic Vehicle Clubs

We are pleased to be members of the Trade Support Scheme of the FBHVC, who strive to “ensure that club members and their vehicles continue to enjoy the freedom of the use of the roads in the United Kingdom and Europe”.



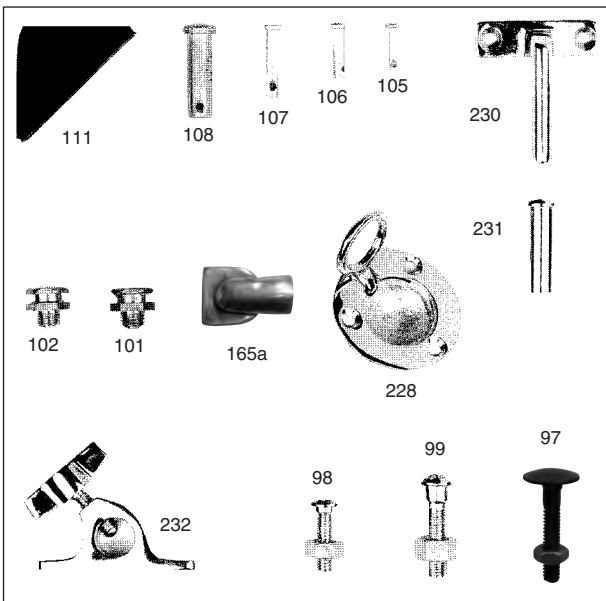

- 230 **Sidescreen Mounting Peg.** 8mm ($\frac{5}{16}$ " dia. 54mm ($2\frac{1}{8}$ " long. Hole centres 35mm ($1\frac{3}{8}$ "). Chrome on brass Each
- 231 **Sidescreen Socket** to accept above peg. 35mm ($1\frac{3}{8}$ " long. Chrome on brass Each
- 232 **Hood Fastener.** Chrome on brass. To suit 16mm ($\frac{5}{8}$ " dia. peg. Mounting hole centres 49mm ($1\frac{15}{16}$ " Each
- 228 **Round Lifting Ring.** 50mm (2") dia. Chrome on brass. Shown with ring raised Each
- Clevis Pins.** Case hardened and zinc plated.
- 105 5mm dia. x 16mm long ($\frac{3}{16}$ " dia. x $\frac{5}{8}$ " long) Each
- 106 6mm dia. x 19mm long ($\frac{1}{4}$ " dia. x $\frac{3}{4}$ " long) Each
- 107 8mm dia. x 24mm long ($\frac{5}{16}$ " dia. x $1\frac{15}{16}$ " long) Each
- 108 10mm dia. x 32mm long ($\frac{3}{8}$ " dia. x $1\frac{1}{4}$ " long) Each
- 97 **Mudguard Bolts.** Domed head 20mm ($1\frac{3}{16}$ ") x 37mm ($1\frac{1}{2}$ ") long with $\frac{1}{4}$ " BSF thread. Steel. Supplied black complete with nut Each
- Bumper Bolts in Chrome**
- 98 25mm (1") long under head x $\frac{5}{16}$ " BSF supplied with nut. Head dia. 14mm ($\frac{9}{16}$ ") Each
- 99 38mm ($1\frac{1}{2}$ ") long under head x $\frac{3}{8}$ " UNF supplied with nut. Head dia. 16mm ($\frac{5}{8}$ ") Each
- 111 **Bonnet Corner Rubbers.** Made from the original Holdtite mould. For right angle corners only Each
- Hex. Grease Nipples in Brass**
- 101 $\frac{3}{8}$ " BSF thread. 15mm ($\frac{19}{32}$ ") across the hex. flats Each
- 102 $\frac{1}{8}$ " BSP thread. 15mm ($\frac{19}{32}$ ") across the hex. flats Each
- 165a **Grease gun adaptor** in brass to fit the above hex. nipples. $\frac{1}{8}$ " gas thread Each

-
- 119 **Spring Binding.** Grease impregnated tape 50mm (2") wide from the makers of the original Drevo tape. Provided that the springs are not over greased before applying the tape, the outer layer hardens to give the appearance of worn leather. Each large leaf spring will take a full 10mtr roll Per roll



155 Leather Renovation Kits. The purpose of this well-tried kit is to restore leather to its original colour with uniform finish and WITHOUT giving the 'just been painted' appearance. Shown above is the No. 2 kit for 4/5 seaters.

Send a specimen of the original leather colour, and we will supply a kit of cleaner, colour matched renovator, sealing paste, cloth and instructions. (When sending a snippet of the old, original leather, [or matching vinyl], make sure that it is CLEANED so that the colour can be matched correctly.) Each kit is individually colour matched and is given a unique colour code. We require a sample by first post on a Tuesday to despatch the kit on Thursday of the same week. (TO BE SAFE, TRY TO ENSURE SAMPLES ARE WITH 'WOOLIES' AT THE BEGINNING OF THE WEEK.) We do have some popular colours in stock for a speedier despatch and when a specific colour match is not required e.g. red, dark blue, beige and magnolia.

In the event of a heavily grained or mottled sample (showing a darker shade in the grain and lighter hue on the high areas) we will supply an **OVERALL MATCH**, unless advised otherwise. We always endeavour to match accurately to the customer's sample, but must insist on the acceptance of 'ARTISTIC TOLERANCE' (ie. slight variance of shade). Rematches can be tricky in this respect.

Kit No. 1 (for 2/3 seaters):

1 x ¼ litre colour renovator	} Per kit
1 x 100ml sealing paste		
1 x ½ litre cleaner		
Cloth		
ALL-IN price UK post paid		

Kit No. 2 (for 4/5 seaters): As above except:

1 x ½ litre colour renovator	Per kit
ALL-IN price UK post paid	

'Jensen' kit (for 4 seats + trim panels): As above except:

1 x 1 litre colour renovator	} Per kit
Cloths		
ALL-IN price UK post paid		

'Limousine' kit (whole interior):

2½ litre colour renovator	} Per kit
3 x ½ litre cleaner		
2 x 100ml sealing paste		
Extra cloths		
ALL-IN price UK post paid		

We can supply individual bottles of renovator	Per ¼ litre
.....	Per ½ litre
.....	Per 1 litre
.....	Per 2½ litre
.....	Per 5 litre

Important: PROTECT LEATHER KITS FROM FROST. Do NOT leave the kit in a cold garage during the winter months.
AVERAGE SHELF LIFE 6 MONTHS.



INSTRUCTIONS

General Guidance:

The keynote to all leather renovation is to obtain adhesion between the leather itself and the first coat of renovator. For upholstery that is well worn, a thorough cleaning with our water based cleaner should be all that is required. However, there COULD be an advantage in using a fine grade steel wool with the cleaner, particularly where the leather has a very smooth, fast finish. This would disturb the surface to give a better 'key'.

STAGE 1

CLEANER – water based, deeply penetrating liquid supplied ready to use. Do **NOT** dilute. Not only cleans but gives deep penetration into the fibres, softening, feeding and therefore increasing the strength of the leather. Apply using a soft cloth rubbing lightly. Avoid flooding and change the surface of the cloth frequently. A small brush can be used to remove the ingrained dirt. It is **ESSENTIAL** that after cleaning, **ALL SURFACES** are thoroughly wiped over with a clean, damp cloth to remove excess build-up of cleaner and dirt.

NB: Thorough cleaning is essential to enable the renovating dye to penetrate the hide.

STAGE 2

COLOUR RENOVATOR – based on materials used in original finishing of upholstery hides in the tannery, and as such is compatible with the leather being restored (5 resins, micronised pigments and water emulsified cellulose lacquer). **STIR WELL BEFORE USE.** Supplied ready to use. Do **NOT** dilute. Pour a small quantity into a saucer. Apply lightly with a soft cloth (NOT a brush) rubbing well into the cracks and crevices, doing small areas at a time. Allow this film to dry out (at least 30 minutes **MINIMUM** at room temperature) and apply a second coat to level off.

Bearing in mind the cost of new leather, it is well worth putting some effort into the task of 'working in' the first coat of renovator. The second coat can be applied by cloth, **OR**, as some customers prefer, by spraying, applying very light coats in order to avoid a rapid, heavy build-up finish.

STAGE 3

SEALING PASTE – to seal the renovator. Apply sparingly and then buff with a soft cloth. **TOO MUCH** elbow grease will tend to remove some of the renovator. Finished surface will have a water resistant wax sheen. 100% cotton cloth supplied with each kit for applying colour and cleaning/buffing.

We feel that it is worth mentioning again that the finished job will retain the original character of the leather and **NOT** have the 'just been painted' appearance. The surface of the leather has not been completely sealed and Hide Care can still be used sparingly after the colour renovation, say every 6 months, to maintain suppleness.

While we do not recommend this kit for completely **CHANGING** the leather colour, this will depend entirely on the colours concerned, i.e., light to dark or black will usually result in a good job. We would suggest that a test area be tackled initially.

With some really **LIGHT** shades (off-white, magnolia etc.) the pale pigment may struggle to give good coverage and a special **BASE COAT** or 'foundation' might help. Cost is much the same as colour renovator. Please contact us **BEFORE** ordering to discuss the project.

We are aware of the problems in getting uniform colour into interiors where seating is **LEATHER** and trim panels in **LEATHERCLOTH/PVC**. However, we have found that the leather renovator will sometimes key onto old, original leathercloths where the surface has been broken down either by wear or cleaning agents. It is certainly worth doing a 'test' piece.

THESE INSTRUCTIONS ARE BASED ON RESEARCH AND PRACTICAL EXPERIENCE. ALTHOUGH WE HAVE EVERY CONFIDENCE IN OUR PRODUCTS, NO GUARANTEE CAN BE GIVEN DUE TO THE WIDE VARIETY OF 'FOREIGN' TREATMENTS TO WHICH THE LEATHER MAY HAVE BEEN PREVIOUSLY SUBJECTED.

Below is a before and after photo from a customer who used the leather renovation kit to renovate his Ferrari seats.



“Having purchased your leather renovation kit and not really expecting brilliant results, if any at all, I was dumbfounded at what I ended up with. I have two new seats for my Ferrari, they honestly look like they have been re-leathered and my friends think the same. If I was a salesman I could go to work happily knowing that what I sell does exactly what it is supposed to.”



46 **Hide Care.** To refurbish and polish leather Each ALL-IN price UK post paid



For all the latest product information and secure on-line ordering visit our website www.woolies-trim.co.uk

221 **HOUSEHOLD Leather Renovation Kit.** For this application, a more permanent finish is required to cope with general wear-and-tear plus spillages. The Stage 3 Sealing Paste is replaced by a bottle of liquid dressing, giving a semi-gloss finish. This special dressing should be applied with a soft sponge and 2 coats are usually required. Please contact us with details of the renovation project and we will be pleased to quote accordingly.

A ROUGH GUIDE to the usage and contents of the kit as follows:

Household Kit No. 1 (for small/medium chair)

½ litre cleaner	} Per kit
¼ litre colour renovator		
¼ litre semi-dressing		
.....		ALL-IN UK post paid

Household Kit No. 2 (for 2 seater settee or 2 chairs)

½ litre cleaner	} Per kit
½ litre colour renovator		
¼ litre semi-dressing		
.....		ALL-IN UK post paid

Household Kit No. 3 (for 3 seater settee plus chair)

½ litre cleaner	} Per kit
1 litre colour renovator		
½ litre semi-dressing		
.....		ALL-IN UK post paid

Quantities will depend on the colour and the condition of the surface to be renovated. (Darker, solid shades cover much better, using less renovator than pale, creamy hues). We cannot reproduce mottled or shady finishes and dramatic COLOUR CHANGES are not recommended.... PLEASE CONTACT US WITH DETAILS OF THE PROJECT BEFORE ORDERING.

WOOLIES always endeavours to match accurately to the customer's sample, but must INSIST on the acceptance of 'ARTISTIC TOLERANCE' (ie slight variance of shade). Rematches can be tricky in this respect.



VINYL RENOVATION



- 373 **Vinyl Paint.** 400ml Aerosol. For re-colouring and changing the colour of interior vinyls. Unique ability to penetrate the surface. Can be used on leather needing any dramatic and permanent colour changes BUT long term 'breathability' may be impaired. For best results use 374 Vinyl Cleaner, followed by 375 Vinyl Primer to etch the surface. Stocked in Black and some basic colours that match our more popular vinyls/l'cloths Per 400ml aerosol. Each **Colour matching available, minimum of 4 aerosols, please enquire.**
- 374 **Vinyl Cleaner.** Dilute before using, for removing dirt, grease and polish/silicone residues which might cause a barrier to the proper surface bonding of Vinyl Paint..... Per 250ml bottle. Each
- 375 **Vinyl Primer.** Spirit based solution that primes the surface and removes any previous old or 'artificial' coatings. It is essential that these are removed first for a good permanent result from Vinyl Paint. Vinyl Primer is fairly potent, so please USE SPARINGLY. We suggest doing a TEST area before plunging-in on the whole project! Per 250ml bottle. Each



MOTOR TRADE

We are keen to develop our Trade business particularly with motor trade and upholstery companies. Overall 10% discount on prices but **ALWAYS** enquire for the best ROLL / BULK DISCOUNTS. Particularly good deals on bonnet tapes and selected rubbers/sponge extrusions and wing pipings.

Please enquire tel 01778 347347

BRASS TAPS AND FITTINGS

Copper Tube. All sizes of this annealed tube are outside dia.

89	1/8" dia. (3mm)	Per mtr	92	5/16" dia. (8mm)	Per mtr
90	3/16" dia. (4.7mm) ...	Per mtr	93	3/8" dia. (9.5mm)	Per mtr
91	1/4" dia. (6.3mm)	Per mtr	Or enquire for roll sizes.		

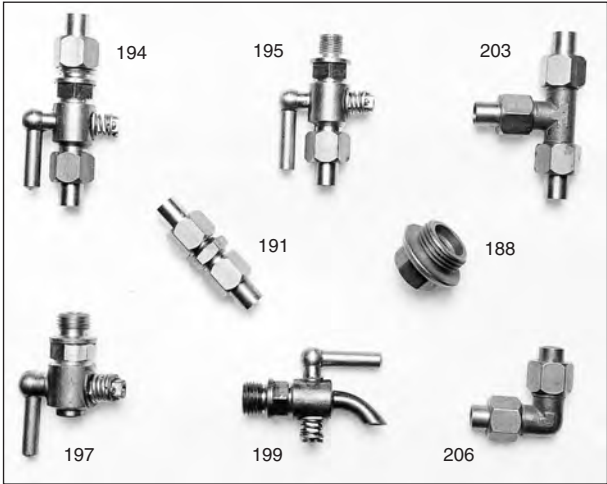

All taps and fittings on this page are shown above with solder type nuts and nipples for 1/4" (6.3mm) pipe.

Drain Plugs

185	1/8" BSP thread	Each
186	1/4" BSP thread	Each
187	3/8" BSP thread	Each
188	1/2" BSP thread	Each

Double Ended Unions complete with solder nuts and nipples

189	1/8" BSP thread for 1/8" tube (3mm)	Each
190	1/8" BSP thread for 3/16" tube (4.7mm)	Each
191	1/4" BSP thread for 1/4" tube (6.3mm)	Each
192	1/4" BSP thread for 5/16" tube (8mm)	Each
193	3/8" BSP thread for 3/8" tube (9.5mm)	Each

194 **Straight Fuel Tap.** 1/4" BSP thread supplied with solder nuts/nipples for 1/4" or 5/16" tube (6.3mm or 8mm). PLEASE SPECIFY

257 **Straight Fuel Tap.** 3/8" BSP thread at each end. Supplied complete with nuts and nipples for 3/8" tube (9.5mm)

195 **Straight Fuel Tap.** 1/8" BSP thread with 1/4" BSP thread holding nut/nipple for 1/4" or 5/16" tube (6.3mm or 8mm). PLEASE SPECIFY

196 **Straight Drain Taps.** 1/8" BSP thread

197 **Straight Drain Taps.** 1/4" BSP thread

198 **Curved Drain Taps.** 1/8" BSP thread

199 **Curved Drain Taps.** 1/4" BSP thread

Tee Pieces. Complete with 3 solder nuts and nipples.

163	For 1/8" tube (3mm)	Each
164	For 3/16" tube (4.7mm)	Each
203	For 1/4" tube (6.3mm)	Each
204	For 5/16" tube (8mm)	Each
205	For 3/8" tube (9.5mm)	Each

Elbows. Complete with 2 solder nuts and nipples.

169	For 1/8" tube (3mm)	Each
170	For 3/16" tube (4.7mm)	Each
206	For 1/4" tube (6.3mm)	Each
207	For 5/16" tube (8mm)	Each
208	For 3/8" tube (9.5mm)	Each

PRICES

All prices include VAT at the current rate.

See the separate easy-to-read price list which is regularly updated. We keep our prices keen, but they may be altered at ANY TIME due to material or manufacturer's increases. You can use the website www.woolies-trim.co.uk to get an all-inclusive price for an order or alternatively telephone or e-mail us.

ORDERING



We accept all major credit and debit cards and PayPal. You can order securely on the website, telephone us on 01778 347347 (0044 1778 347347 for overseas customers) or e-mail us info@woolies-trim.co.uk

CARRIAGE COSTS

Orders which are under 2 kilos in weight and not too valuable will usually be sent by Royal Mail 1st class post. Larger and heavier items will be sent by courier where a signature is required. Postage prices vary and start at £3.90 for a small 1st class order. Please contact us to get an accurate price for your order or use the website, if you put items in your shopping basket on the website it will calculate the cost of postage.

Please note if you need express delivery we can do timed deliveries e.g. Next Day before 12 noon or 10.30am, please enquire.

DELIVERY

All items (except colour matched leather kits) are usually in stock and we endeavour to despatch all orders received by 2.30pm the same day. We will inform you by return if any goods ordered are currently unavailable. It may be possible to despatch orders received after 2.30pm the same day, it is dependent on how busy we are. If you require an order urgently it is advisable to telephone us to see if it can be despatched same day.

GUARANTEE

We will replace or refund for any goods returned, but will make a MINIMUM 15% handling charge, unless we make alternative arrangements. Specifically ordered **CUT lengths** are DIFFICULT to re-sell and therefore **NOT** welcome as returns! No goods will be accepted for credit unless returned to us within 14 days of the date of invoice. We have tried to give a brief but accurate description of all items in this brochure to comply with the Trade Descriptions Act. Should any customers think that there is any misrepresentation at all, will they please advise us so that the matter can be amended for future editions.

SHOWS AND AUTOJUMBLES

We attend a select number of Shows and Autojumbles each year, please look at the website for an up to date listing of where you can find us. We can bring orders to the event for collection saving you the cost of postage.



HOW TO FIND WOOLIES . . .

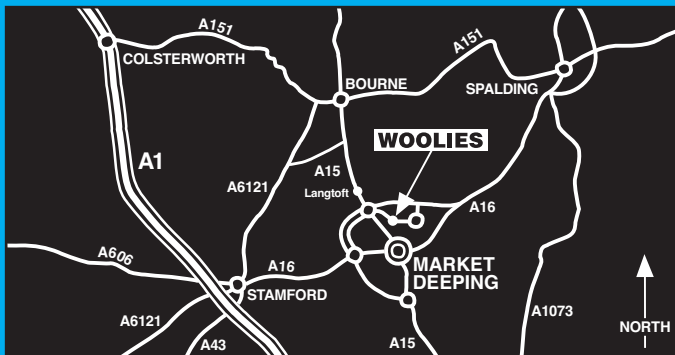

Access to the Northfields Industrial Estate is directly from the Market Deeping bypass. From the northern roundabout take the exit signed for Northfields Ind. Estate. This leads into Blenheim Way and Whitley Way is the first left. Woolies is the first building on the left.

FROM THE NORTH (on A15 south from Bourne) ... pass through Langtoft village. In approx. 1 mile, take 2nd exit from the roundabout, then as above.

FROM THE WEST (on A16 from Stamford) ... turn left at the new Welland Gate roundabout and onto the dual carriageway section of the Market Deeping bypass. At next roundabout take 3rd exit, then as above.

FROM THE SOUTH (on A15 from Peterborough) ... take the A15/A16 Market Deeping bypass from the Northborough roundabout. Continue straight on at the next (Welland Gate) roundabout, onto the dual carriageway section. At the next roundabout take 3rd exit, then as above.

FROM THE EAST (on A16 from Spalding) ... take the left turn onto Northfields Industrial Estate, then turn right at the roundabout. Continue along Whitley Way and Woolies is on the right just before the T junction.



WOOLIES (I & C Woolstenholmes Ltd)
Whitley Way, Northfields Industrial Estate,
MARKET DEEPING, PETERBOROUGH,
England, PE6 8AR
Tel: (01778) 347347
www.woolies-trim.co.uk
info@woolies-trim.co.uk